

**HYUNDAI**  
POWER PRODUCTS

# **COMPACTOR PLATE**

## **HYCP5030 HYCP6570 HYCP9070**

---

**User Manual**

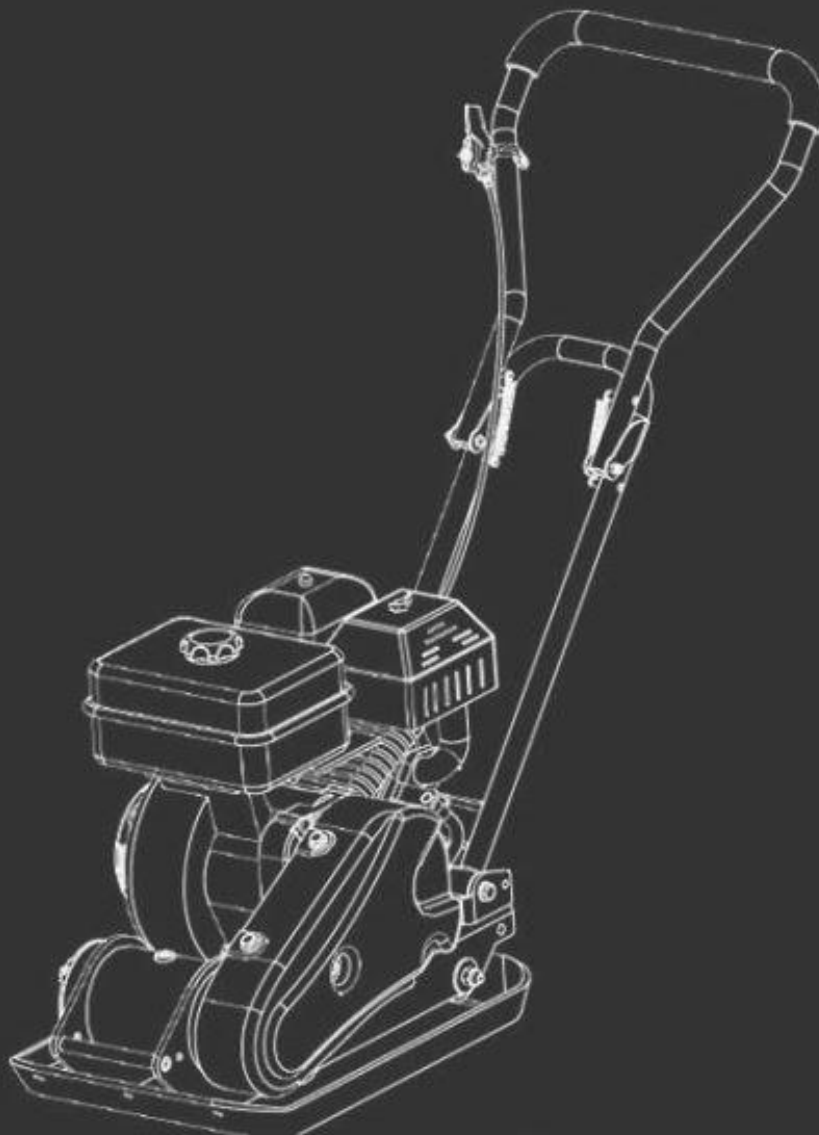

# INDEX

	CONTENTS	PAGE NO.s
1	SAFETY	3 – 8
2	PART LOCATIONS	9
3	ASSEMBLY	10 – 13
4	PRE-OPERATION CHECKS	12
5	STARTING PROCEDURE	13 – 14
6	STOPPING PROCEDURE	14
7	OPERATING INSTRUCTIONS	15 – 16
8	MAINTENANCE	16 – 23
9	TRANSPORTATION & STORAGE	24
10	TROUBLESHOOTING	25
11	SPECIFICATION	26
12	DECLARATION OF CONFORMITY	27
13	RECYCLING & PRODUCT DISPOSAL	28
14	CONTACT DETAILS	29
15	WARRANTY	29
16	MANUAL UPDATES	29

# 1. SAFETY

## 1.1 General Safety Notes.

- 1.2 The operator of the machine is responsible for, and has a duty of care in making sure that the machine is operated safely and in accordance with the instructions in this user manual. Keep the manual safe and pass it on if the machine is loaned or sold to another user.
- 1.3 Please note the following safety points.
- 1.4 The machine should never be left in a condition which would allow an untrained or unauthorised person/s to operate this machine.
- 1.5 All due care and diligence should be taken by the operator for the safety of and with regard to those around whilst using the machine.
- 1.6 Some or all of the following - warning signs, symbols and/or PPE pictograms may appear throughout this manual. You **MUST** adhere to their warnings. Failure to do so may result in personal injury to yourself or those around you.



## DANGER

Indicates a hazard, which, if not avoided, could result in serious injury or death.



## WARNING

Indicates a hazard, which, if not avoided, could result in serious injury.



## CAUTION

Indicates a hazard which, if not avoided, might result in minor or moderate injury.



## NOTE

Indicates a situation that could easily result in equipment damage.

READ and keep the manual safe and pass it on if the machine is loaned or sold to another user.

You **MUST** fully understand all instructions to ensure you use and operate the machine safely.

Appropriate Personal Protective Equipment (PPE), **MUST** be worn at all times when operating or repairing the machine.



HAND PROTECTION MUST BE WORN



EYE PROTECTION MUST BE WORN



PROTECTIVE CLOTHING MUST BE WORN



HEARING PROTECTION MUST BE WORN



FOOT PROTECTION MUST BE WORN



HEAD PROTECTION MUST BE WORN



RESPIRATOR MUST BE WORN



FACE SHIELD MUST BE WORN

1.10 Carbon Monoxide (where applicable).

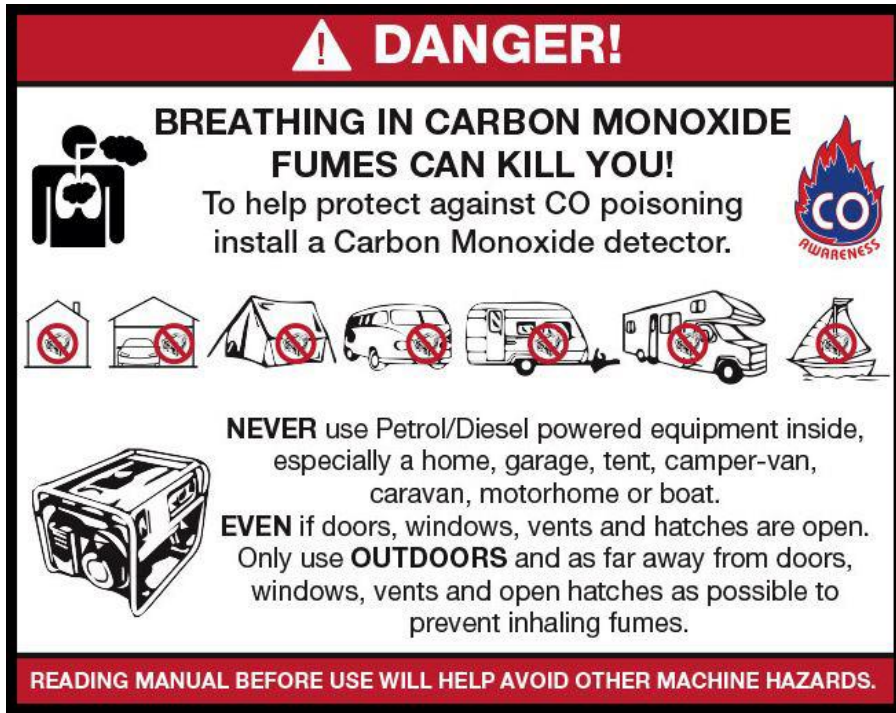

- 1.11 Carbon monoxide is a colourless and odourless gas. Inhaling this gas can cause death as well as serious long term health problems such as brain damage.
- 1.12 The symptoms of carbon monoxide poisoning can include but are not limited to the following;  
Headaches, dizziness, nausea, breathlessness, collapsing or loss of consciousness.
- 1.13 Carbon monoxide poisoning symptoms are similar to flue, food poisoning, viral infections and simply tiredness. It is quite common for people to mistake this very dangerous poisoning for something else.
- 1.14 To avoid carbon monoxide poisoning **DO NOT** use Petrol/Diesel powered equipment inside any of the following; Home, garage, tent, camper van, mobile home, caravan or boat. This is not exhaustive and if you are in any doubt contact your dealer.
- 1.15 If you think you have or someone around you has been affected by carbon monoxide poisoning;
- 1.16 Get them fresh air immediately, by leaving the affected area or by opening doors and windows. If safe and practical to do so make sure that the machine is turned off. **DO NOT** enter a room you suspect of having carbon monoxide present – instead call the emergency services.
- 1.17 Contact a Doctor immediately or go to Hospital – let them know that you suspect carbon monoxide poisoning.
- 1.18 **DO NOT** use in an enclosed area or moving vehicle.

## 1.20 General Fuel Safety (where applicable).



### CAUTION

#### ALL FUELS ARE FLAMABLE

1.21 Fire Hazard – keep fuel away from all sources of ignition for example heaters. Lamps, sparks from grinding or welding.



1.22 **DO NOT** carry out hot work on tanks that have contained fuel.

1.23 **ALWAYS** keep the work area tidy.

1.24 **ALWAYS** clean up spills promptly using absorbent granules and a lidded bin.

1.25 **ALWAYS** dispose of waste fuels correctly.

## 1.30 Fueling/De-fueling (where applicable).



### CAUTION

#### ALL FUELS ARE FLAMABLE

1.31 **ALWAYS** fuel and defuel in a well ventilated area outside of buildings.

1.32 **ALWAYS** wear correct, suitable and fit for purpose Personal Protective Equipment (PPE), suggested items are but not limited to safety gloves, overalls.



1.33 When fueling/de-fueling **ALWAYS** avoid inhaling fumes.

1.34 When de-fueling **ALWAYS** use a proper fuel retriever.



1.35 **ALWAYS** carry fuel in the correct and clearly marked container.

## 1.40 Electrical Safety (where applicable).

1.41 Electricity can kill – **NEVER** work on **LIVE/ENERGISED** equipment.

1.42 Prior to carrying out any maintenance work you **MUST** identify electrical isolation methods and isolate all electrical supplies.

1.43 Prior to use and with all electrical supplies isolated, you **MUST** check all electrical cables, plugs and connectors for the following;

1.44 Are intact and have no signs of damage, to include but not limited to bare wires, chaffing, cuts and loose wiring.

1.45 If there are any signs of damage, the damaged item **MUST** be taken out of service until the damage has been repaired by an electrically competent person.

1.46 All trailing cables should be routed so as not to cause any kind of trip hazard.

1.47  **NEVER** work on or near electricity with wet hands, wet clothing and wet gloves.



### 1.50 **Batteries (where present).**

1.51 Batteries present a risk if they become damaged by the possible leaking of electrolyte. This electrolyte is an acid and can cause serious burn injuries. Care should be taken when working on or near them. **NOTE** the electrolyte may be in a liquid or gel form.

1.52 Should you come in to contact with electrolyte you should;

1.53 Remove all clothing contaminated with electrolyte. If you cannot remove then saturate them in water.

1.54 Get medical assistance as soon as possible. You must advise the medical staff of the type of acid.

1.55 Lead/acid battery = dilute sulphuric acid.

1.56 Nickel/cadmium = potassium hydroxide alkali electrolyte.

1.57 Use fresh running water to wash off excess electrolyte, continue this until medical assistance arrives. Make sure that you do not wash the electrolyte to another part of your body or face.

1.58 If electrolyte comes in to contact with Eyes the electrolyte needs to be immediately washed away with large amounts of water. Make sure that you do not wash the electrolyte to another part of your face or body.

1.59 Gasses from charging batteries are highly flammable and great care should be taken to charge in well ventilated areas.

1.59.1  There is an explosion risk if the battery terminals are short circuited, when connecting/disconnecting **ALWAYS** exercise great care so that the terminals or battery leads are **NOT** allowed to touch and cause a spark. **ALWAYS** use suitable insulated tools.



### 1.60 **Vibrations (where applicable).**

1.61 Prolonged use of hand held (operated) machines will cause the user to feel the effects of/from vibrations. These vibrations can lead to white finger (Raynaud's phenomenon) or carpal tunnel syndrome. This condition reduces the ability of the hand to feel and regulate temperature, causing numbness and heat sensations and may cause never damage and circulatory tissue death.

1.62 Not all factors that lead to white finger disease are known, but cold weather, smoking and other diseases that affect blood vessels and blood circulation as well as large and long-lasting impact of shocks are considered factors in the formation of white finger. Note the following to reduce the risk of white finger and carpal tunnel syndrome;

1.63 Wear gloves and keep your hands warm.

1.64 Take regular breaks.

1.65 All of the above precautions may help reduce the risk of white finger disease but not rule out the carpal tunnel syndrome. Long-term and regular users are therefore

recommended to observe the condition of your hands and fingers. Seek medical attention immediately if any of the above symptoms should occur.

## 1.70 Noise (where applicable).

- 1.71 The operating noise of the machine can damage your hearing. Wear hearing protection such as earplugs or ear defenders to protect your hearing. Long-term and regular users are advised to have hearing checked regularly. Be especially vigilant and cautious when hearing ear protection because your ability to hear alarm warnings will be reduced.
- 1.72 Noise emissions for this equipment is unavoidable. Carry out noisy work at approved times and for certain periods. Limit the working time to a minimum. For your personal protection and protection of people working nearby it is also advisable for them to wear hearing protection.
- 1.73  See Certificate of Conformity section for Outdoor Noise declaration of conformity.

## MACHINE SPECIFIC SAFETY

### 1.80 General Machine Safety.

- 1.81 Read the owner's manual carefully to understand how to operate this machine properly.
- 1.82 You should **NEVER** use the machine when;
- 1.83 Wearing loose clothing, barefoot or sandals.
- 1.84 Under the influence of drink or drugs or as a result of having taken medication for cold or flu, or any other times when a possibility exists that your judgement might be impaired or that you might not be able to operate the machine properly and in a safe manner.
- 1.85 Suffering from exhaustion or lack of sleep.
- 1.86 When the ground is slippery or when other conditions exist which might make it not possible to maintain a steady posture.
- 1.87 At night, at times of heavy fog, or at any other times when your field of vision might be limited and it would be difficult to gain a clear view of the area.
- 1.88 During rain storms, lightning storms, at times of strong or gale force winds, or at any other times when the weather conditions might make it unsafe to use this product.
- 1.89 **NEVER** run the engine indoors. The exhaust gasses contain harmful carbon monoxide.
- 1.90 When using this machine for the first time and before actual work, you **MUST** learn how to handle the machine from an experienced or skilled person.
- 1.91 Limit the amount of time using the machine continuously to somewhere around 10 minutes per session and take 10 to 20 minutes of rest between sessions. Also try to keep the total amount of work in a single day limited to 2 hours or less.

- 1.92 **NEVER** allow children or anyone unable to fully understand the directions given in this manual to operate this product.
- 1.93 Make sure you keep this manual handy so you may refer to it whenever questions arise and ensure you pass this manual on if the machine is loaned or sold.
- 1.94 Correct Personal Protective Equipment (PPE) **MUST** be worn at all times when operating or repairing this machine. This should include but is not limited to;



HAND  
PROTECTION  
MUST BE WORN



EYE  
PROTECTION  
MUST BE WORN



PROTECTIVE  
CLOTHING  
MUST BE WORN



HEARING  
PROTECTION  
MUST BE WORN



FOOT  
PROTECTION  
MUST BE WORN



HEAD  
PROTECTION  
MUST BE WORN



RESPIRATOR  
MUST BE WORN



FACE SHIELD  
MUST BE WORN



## 2. PART LOCATIONS

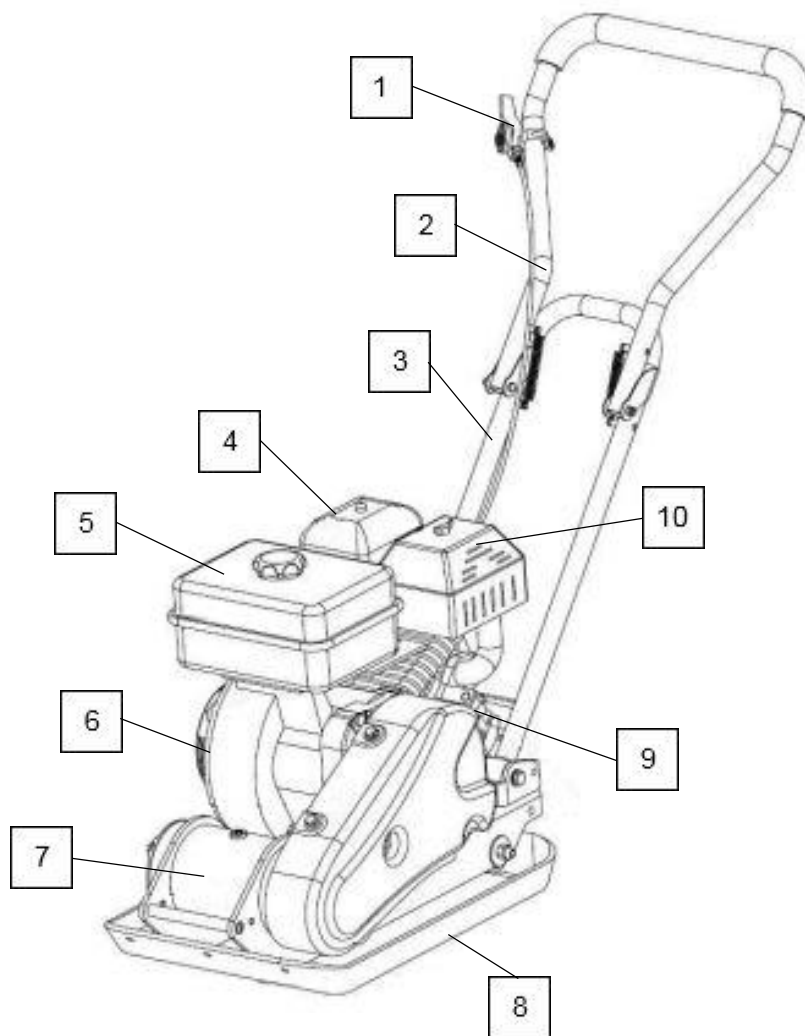

1	Throttle Control	6	Engine
2	Upper Handle	7	Exciter
3	Lower Handle	8	Base Plate
4	Air Filter	9	Oil Drain Port
5	Fuel Tank	10	Exhaust

### 3. ASSEMBLY



#### CAUTION

Due to the weight of this machine, it is advisable to seek assistance with assembly.  
Check all parts are present before beginning assembly.

#### HANDLE

- 3.1 Unfold the upper handle.

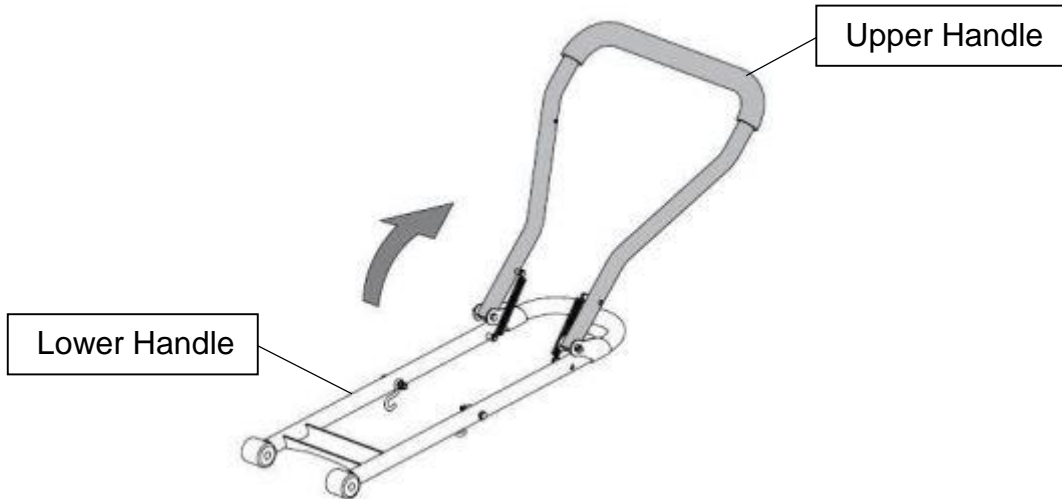

- 3.2 Mount the lower handle to the mounting points on either side of the compactor plate deck.

- 3.3 Mount the throttle control lever to the mounting point on the upper handle.

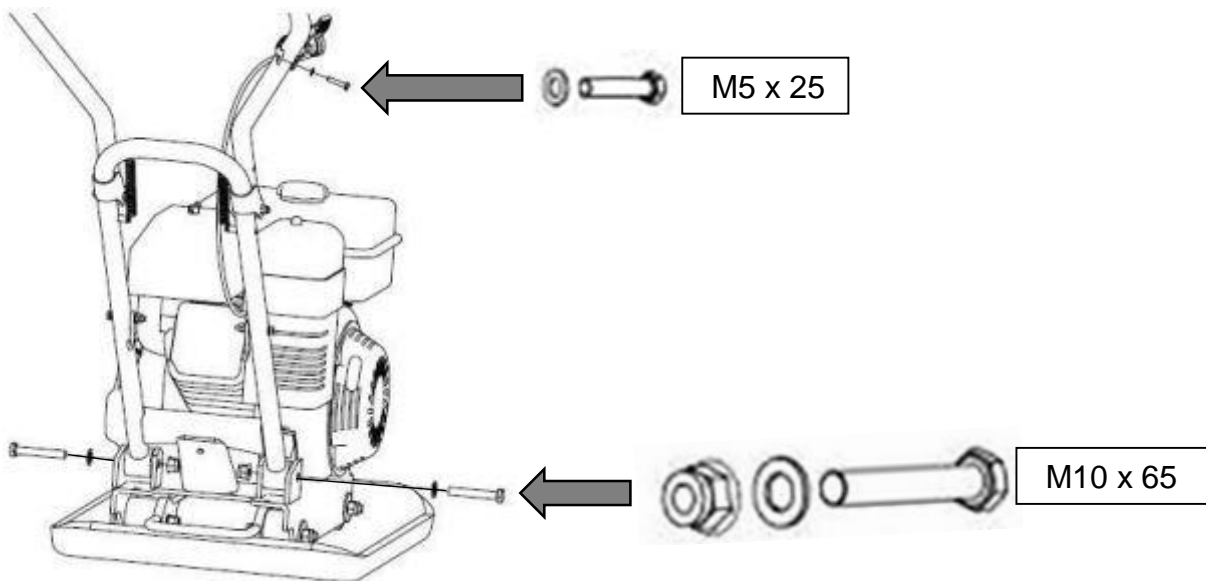

## WHEEL KIT

- 3.4 Align the holes in the wheel kit with the mounting points on either side of the compactor plate deck and secure in place.

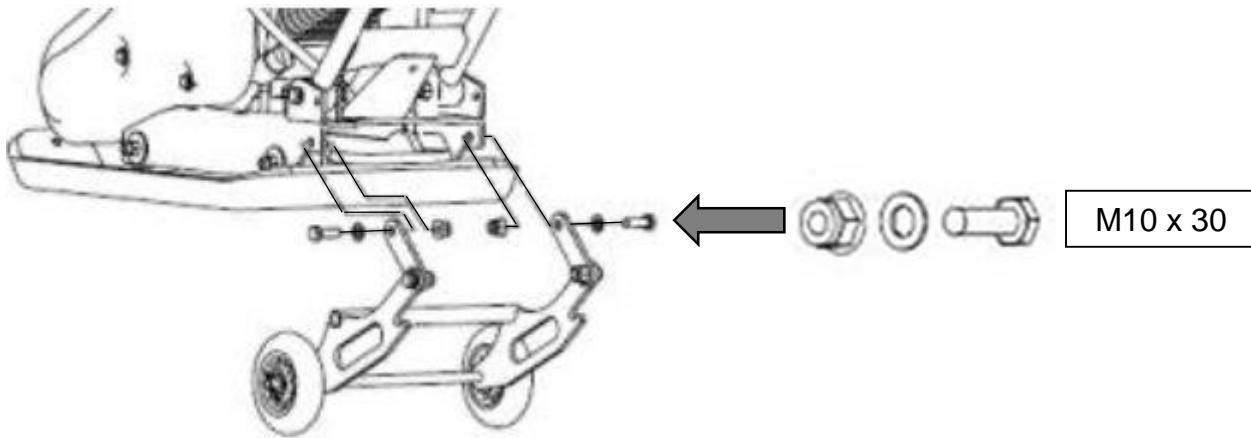

- 3.5 Before using the compactor plate, you **MUST** fold up the wheel kit.

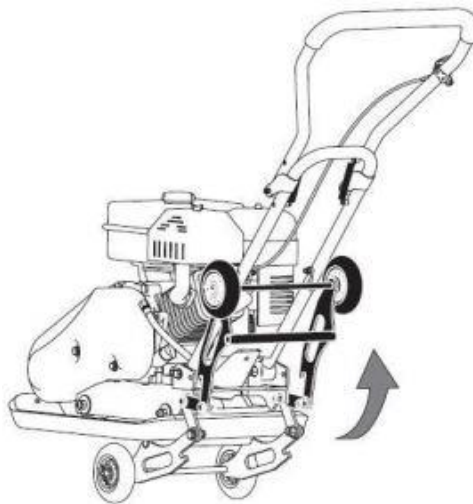

- 3.6 Attach the paving pad (if required) by aligning the holes on the base plate with the holes in the paving pad and mounting plate.

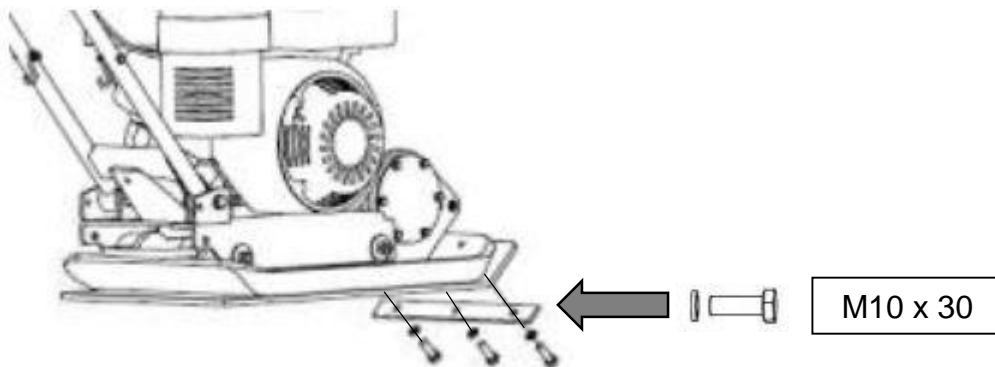

## 4. PRE OPERATION CHECKS



### NOTE

This machine is shipped without fuel and oil in the engine. It is essential that fuel and oil levels are checked and maintained before each operation.

**ALWAYS** check the fuel and oil level with the machine on flat level ground.

Fuel Type	Unleaded Petrol
Engine Oil Type	SAE30 or SAE15W40 Engine Oil



### CAUTION

#### FOR OUTDOOR USE ONLY

This machine produces carbon monoxide – a poisonous, colourless and odourless gas that can cause death or serious injury.



### CAUTION

#### ALL FUELS ARE FLAMMABLE

**ALWAYS** handle with extreme care and in a well-ventilated area.

Allow the engine to cool and remove the spark plug HT lead cap before refuelling or defueling.

## FUEL

- 4.0 Place the machine on flat level ground in a well-ventilated area away from any sources of ignition and at least 1.5m away from any buildings.
- 4.1 Clean the area around the fuel filler cap to prevent dirt and debris from entering the fuel system.
- 4.2 Unscrew the fuel filler cap and slowly fill with unleaded petrol. You **MUST** allow a 25mm gap between the top of the fuel and the top of the fuel tank to allow for fuel expansion.
- 4.3 Refit the fuel filler cap securely and wipe up any spills.

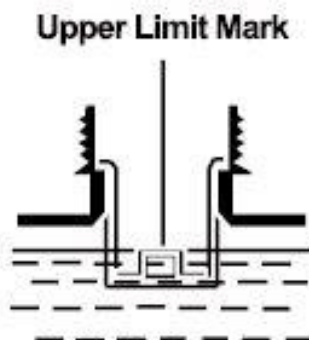

## ENGINE OIL

- 4.4 Place the machine on a flat level surface.
- 4.5 Clean the area around the oil filler cap/dipstick to prevent dirt and debris from entering the engine.
- 4.6 Unscrew and remove the oil filler cap/dipstick.
- 4.7 For machines without a dipstick, the oil level is determined by filling to the upper thread level.  
For machines with a dipstick, the oil level is determined by the upper level limit mark on the dipstick.
- 4.8 Slowly fill with oil to the correct level. Stop occasionally and check the level.  
**DO NOT** overfill.
- 4.9 Once full, refit the oil filler cap/dipstick and tighten securely.

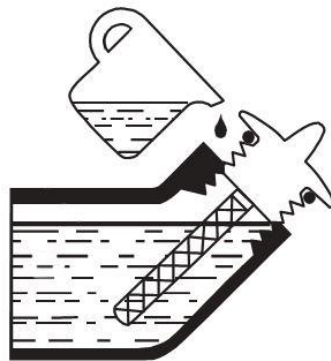

## 5. STARTING PROCEDURE



### NOTE

This machine is shipped **WITHOUT** fuel and oil and will require filling **BEFORE** use. Failure to do so will result in engine damage that will not be covered by the warranty.



### CAUTION

Before starting, ensure the machine is clear of materials and all non-essential persons.

- 5.0 Move the fuel tap to the 'ON' position and turn the ignition switch to the 'ON' position.

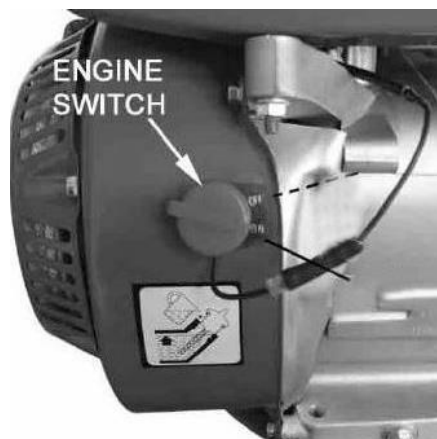

- 5.1 **COLD START:** Move the choke lever to the 'START' position.  
**WARM START:** Leave the choke lever in the 'RUN' position.

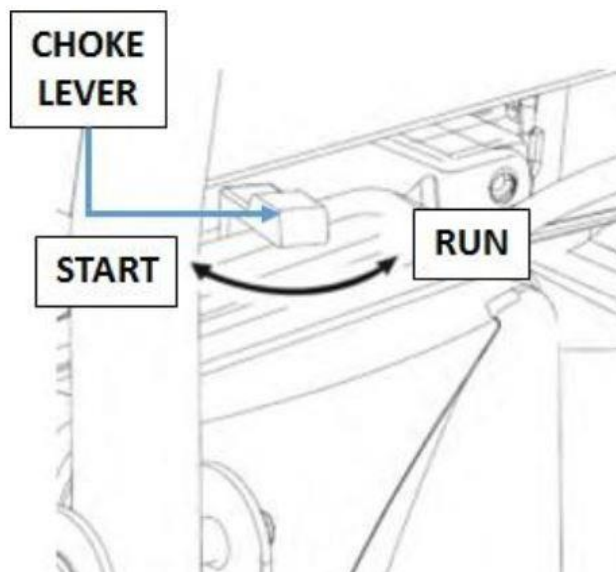

- 5.2 Gently pull the recoil start handle until you feel resistance, then pull swiftly.
- 5.3 Repeat until the engine starts.  
**DO NOT** let go of the recoil handle, instead return the handle to the start position slowly.
- 5.4 Once the engine has started, move the choke lever between the **START/RUN** positions and adjust until the engine runs smoothly.
- 5.5 Once the engine has warmed up, move the throttle lever on the handlebars to the desired working speed.

## 6. STOPPING PROCEDURE

- 6.0 Move the throttle lever to the SLOW position.
- 6.1 Allow the engine to sit at idle under no load for 20 seconds.
- 6.2 Turn the engine switch to the 'OFF' position.
- 6.3 Turn the fuel tap to the 'OFF' position.

## EMERGENCY STOP

- 6.4 In an emergency, move the engine switch to the 'OFF' position.  
**NOTE:** Only use in case of emergency as continual use of the emergency stop procedure could cause damage to the machine.

## 7. OPERATING INSTRUCTIONS



### NOTE

This machine is shipped **WITHOUT** Oil and Fuel and will require filling **BEFORE** use. Failure to do so will result in engine damage that will not be covered by the warranty.



### WARNING

You **MUST STOP** the machine if any of the following occur;  
The engine speed changes with no control.  
In case of misfire or unusual noise.  
In case of high vibration.  
In rain or stormy weather.



### CAUTION

#### FOR OUTDOOR USE ONLY

This machine produces carbon monoxide – a poisonous, colourless and odourless gas that can cause death or serious injury.  
Petrol is highly flammable, always handle with extreme care and in a well-ventilated area.

**ALWAYS** remove the HT lead from the spark plug when checking the machine, refuelling or changing parts.





### CAUTION

If you are not familiar with this type of machine, you should seek advice and guidance from your dealer.

**DO NOT** attempt to lift the machine with the engine running.

- 7.0 After the engine warms up, pull the throttle lever to accelerate the engine speed.
- 7.1 The plate will begin vibrating and begin to move forward.
- 7.2 The plate compactor is designed to run at an engine speed (engine take off shaft) of 3600rpm (normally considered full throttle).
- 7.3 Running the engines at lower rpm's will result in a decrease in compaction force and a lower travel speed.  
It will create excessive 'out-of-sync' vibrations resulting in poor compaction, manoeuvrability, excessive wear to the machine and discomfort for the operator.
- 7.4 In operation, guide the machine but let the compactor do the work.
- 7.5 Bearing down on the handle is unnecessary and will cause shock absorber wear.
- 7.6 On level surfaces the compactor moves forwards rapidly.
- 7.7 On uneven surfaces or inclines, light forward pressure on the handle may be required to assist the compactor in moving forward.
- 7.8 The number of passes required to reach a desired compaction level will depend on the type and moisture content of the soil.
- 7.9 Maximum compaction has been reached when excessive kickback is noticed.

- 7.10  **NOTE**  
When using a compactor on asphalt, a water sprinkler kit (not included) is required to help prevent the bottom plate from adhering to the hot asphalt surface.
- 7.11  **NOTE**  
When using on paving stones or similar, attach a paving pad to the bottom of the plate to prevent the compactor from marking or chipping the surface of the stones.
- 7.12  
While a certain amount of moisture in the soil is necessary, excessive moisture can cause soil particles to stick together and prevent good compaction.  
If the soil is extremely wet, allow to dry before compacting.
- 7.13  
If the soil is as dry to cause dust clouds while operating the plate, some moisture should be added to the ground material to improve compacting.  
This will also reduce air filter servicing.

## 8. MAINTENANCE



### **WARNING**

**ALWAYS** stop the engine, allow it cool and remove the spark plug HT lead cap before doing any maintenance or repairs.

Check and maintain the oil and fuel levels regularly.

At regular intervals check the tightness of all nuts, bolts and screws.

If the machine hits an obstacle, stop and check for damage.

Any damage must be repaired before continuing to use the machine.



### **CAUTION**

**ALWAYS** fuel and defuel in a well-ventilated area with the engine off and allowed to cool.

Whilst carrying out any maintenance, you **MUST** wear the appropriate Personal Protective Equipment (PPE).



### **CAUTION**

**NEVER** use a pressure washer or hosepipe to clean the machine.

Water can penetrate areas of the machine and cause damage to the spindles, pulleys, bearings and engine.

The use of a pressure washer or hosepipe will shorten the lifespan and reduce serviceability.



### **NOTE**

Only use manufacturer recommended parts when servicing or repairing this machine. The use of non-recommended parts may shorten the machines lifespan and void the warranty.



		Each Use	1 <sup>st</sup> Month or 20 Hours	Every 50 Hours	Every 6 Months or 100 Hours	Every Year or 300 Hours
Engine Oil	Check	●				
	Replace		●		●	
Air Filter	Check	●				
	Replace			●		
Spark Plug	Check		●			
	Replace				●	
Fuel Filter	Clean					
	Replace					●
Spark Arrestor	Clean				●	
Belt Tension	Check		●	●		
Fuel Lines	Check	●				
Fuel Tank	Check				●	
Idle Speed	Check					# ●
	Adjust					# ●
Valve Clearance	Check					# ●
	Adjust					# ●

# We recommend these service items are carried out by an authorised service dealer.

## ENGINE OIL



### CAUTION

Risk of Burn from hot oil.  
Allow the oil to cool to WARM before changing.  
Warm engine oil will drain effectively.

Oil Type	SAE30 or SAE15W40 Engine Oil
----------	------------------------------

- 8.0 Drain the engine oil while the engine is warm. Warm oil will drain more effectively.
- 8.1 Clean the area around the oil filler/dipstick and do not allow any dirt or debris to enter the engine.
- 8.2 Remove the oil filler/dipstick and place a suitable container underneath the oil drain plug.
- 8.3 Unscrew the oil drain plug and allow the oil to drain.
- 8.4 Once the oil has drained, check the drain plug for damage. If damaged, replace immediately.
- 8.5 Reinstall the drain plug by hand to avoid cross threading, once seated tighten securely.
- 8.6 With the machine on flat level ground, slowly fill with fresh engine oil. Stop occasionally to check the level.
- 8.7 For machines fitted with a dipstick, fill to the upper level mark on the dipstick. For machines without a dipstick, fill to the upper thread level on the oil fill hole.
- 8.8 Refit the oil filler cap/dipstick securely.
- 8.9 Wipe up any spilt oil.

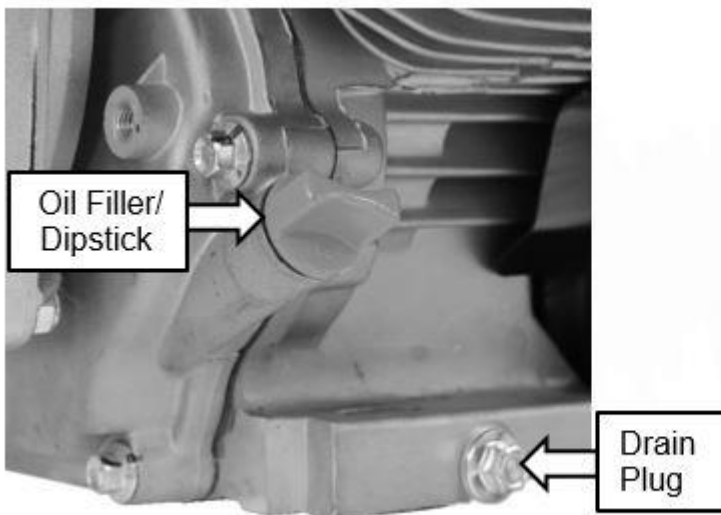

## AIR FILTER



### NOTE

**NEVER** run the machine without an air filter being installed.

A dirty air filter element affects the engine performance, increases fuel consumption and will make it difficult to start.

If you notice a loss of power, check the air filter.

You must ensure that the air filter housing is free of dust and debris. **DO NOT** allow any dirt or debris to enter the carburettor.

- 8.10 Remove the air filter cover by unscrewing the air filter cover wing nut and remove the cover.
- 8.11 Undo the air filter element wing nut and remove the air filter element.
- 8.12 Ensure that no dirt or debris can enter the carburettor.
- 8.13 Remove the foam filter element (if installed) from the paper element.
- 8.14 Inspect the air filter and if it shows any signs of damage or wear, replace immediately.
- 8.15 Tap the paper element to remove dirt and debris and use a low pressure air-line to blow from the inside of the element to remove the remaining dust.
- 8.16 If installed, wash the foam element in a warm soap solution and allow to air dry. **DO NOT** twist the element to dry.
- 8.17 Once dry, soak the foam element in fresh engine oil and remove any excess.
- 8.18 Reinstall the foam element over the paper element and reinstall back on to the machine.

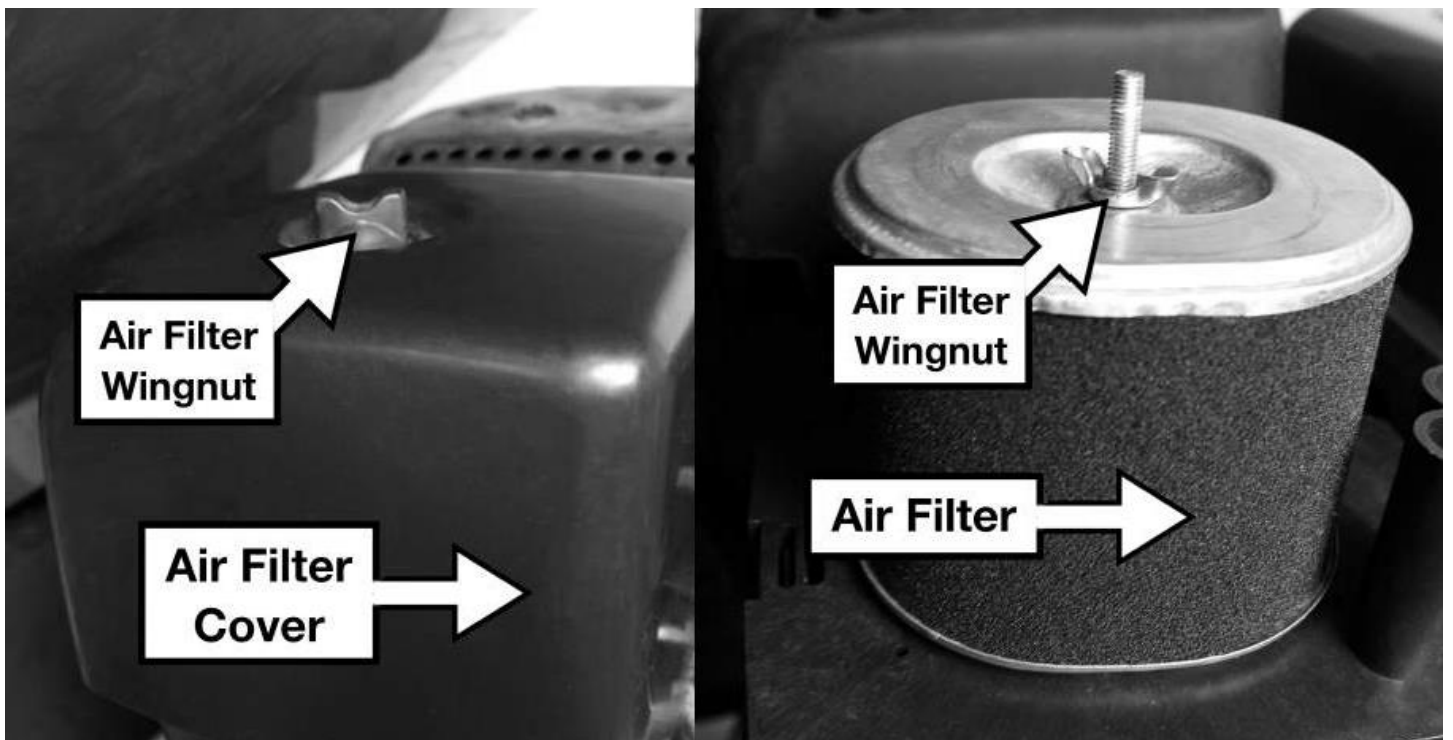

## SPARK PLUG



### CAUTION

**ALWAYS** allow the engine to cool completely before removing the spark plug.



### NOTE

**ALWAYS** replace the spark plug with the same model.

Incorrect spark plug installation can cause serious engine damage.

**DO NOT** allow dirt or debris to enter the cylinder bore.

- 8.19 Remove the spark plug HT lead cap.
- 8.20 Using a plug wrench, unscrew the spark plug in an anti-clockwise direction.
- 8.21 Inspect the spark plug and spark plug washer for any signs of wear or damage. If the plug show any signs of wear or damage, the replace immediately.
- 8.22 Remove any carbon deposits from the spark plug electrode by using a soft wire brush.
- 8.23 The spark plug gap should be 0.70 – 0.80 mm (0.028” – 0.031”). Check the plug gap by using a feeler gauge. The gauge must drag a little when being slid between the electrodes.

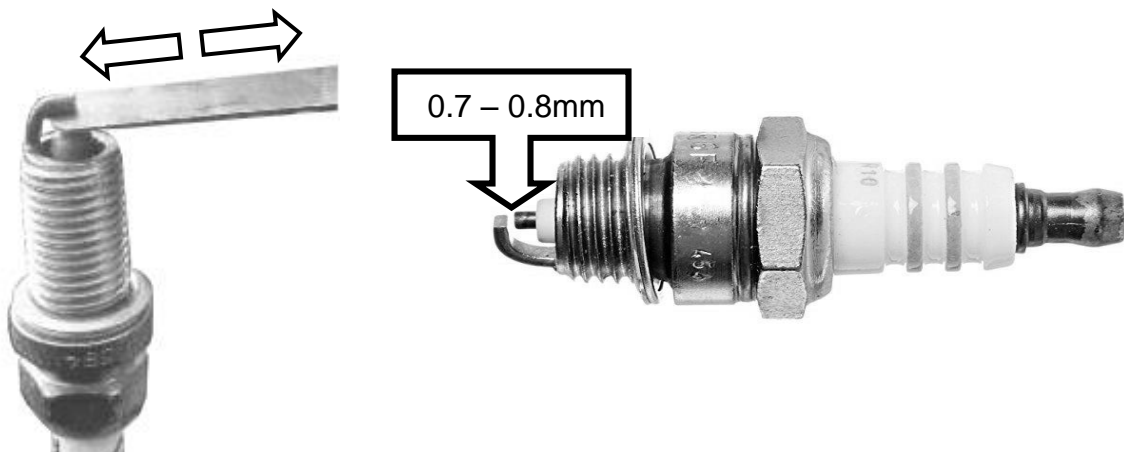

- 8.24 Refit the spark plug by hand to avoid cross threading.
- 8.25 Once the spark plug seats, tighten the spark plug to a torque of 12 to 15Nm.

## TENSIONING BELTS

### Tensioning the Belt(s)

**NOTE:** The normal belt deflection on each side should be 9 to 13mm. This should be checked after the first 20 hours use then every 50 hours thereafter.

- 8.26 Proper belt tensioning is critical to good performance and will ensure long belt life. Too much or too little belt tension will cause premature belt failure.
- 8.27 Undo and remove the belt guard.

- 8.28 Loosen the four engine mount bolts (do not remove) only enough to move the engine forward.
- 8.29 Loosen the jam nuts (B) leaving enough space between the nut and bracket.

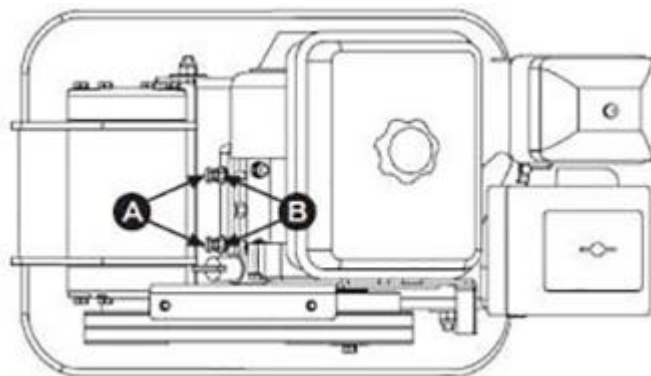

- 8.30 Push the engine toward the back of the plate by turning the adjustment bolts A to remove any slack in the V-belt(s).

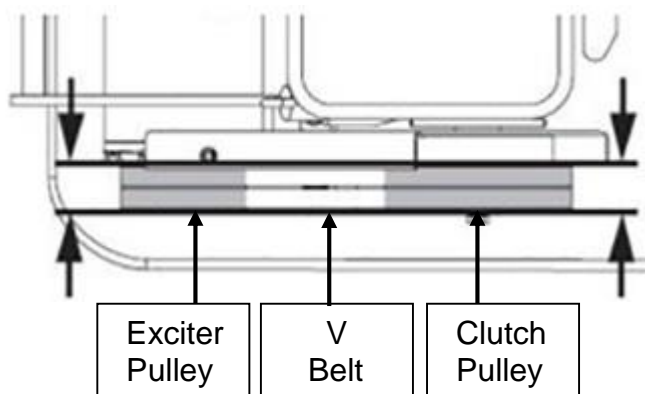

- 8.31 When adjusting the belt(s), make sure that the clutch pulley is in alignment with the exciter pulley.
- 8.32 When the V-belt tension is correct, tighten the jam nuts B against the bracket.
- 8.33 Tighten the engine mount bolts.
- 8.34 Replace the belt guard.
- 8.35  **NOTE:** If the adjustment bolts have no more adjustment left, the belt(s) may have to be replace.

**Replacing the V Belt(s)**



**NOTE**

For models HYCP6570 & HYCP9070 both V belts should be replaced at the same time because they will wear evenly through normal use. Work on one belt at a time.

- 8.36 Undo and remove the belt guard.
- 8.37 Loosen the 4 engine mount bolts (do not remove) only enough to move the engine forward.

- 8.38 Loosen the jam nuts B and bolts A.
- 8.39 Slide the engine toward the front plate and slip the V Belt(s) off the pulley.
- 8.40 Install the new belt.
- 8.41 Position the V belt(s) over the engine pulley.
- 8.42 Move the engine back.
- 8.43 **NOTE:** When adjusting the belt(s), make sure that the clutch pulley is in alignment with the exciter pulley.
- 8.44 When the V-Belt tension is correct, tighten the Jam nuts B and the engine mount bolts.
- 8.45 Replace the belt guard.

## EXCITER LUBRICATION

**Agitator is pre-filled with oil. Change oil every 200 hours use.**

	HYCP5030	HYCP6570	HYCP9070
Exciter Oil Capacity – ml	120	150	150
Exciter Oil Type	SAE30 or 15W40		

- 8.46 Allow the exciter to cool before changing the oil.
- 8.47 Remove the belt guard and V-belt(s).
- 8.48 Remove the bolts that hold the deck to the housing and lift the entire deck, with engine, away from the housing.

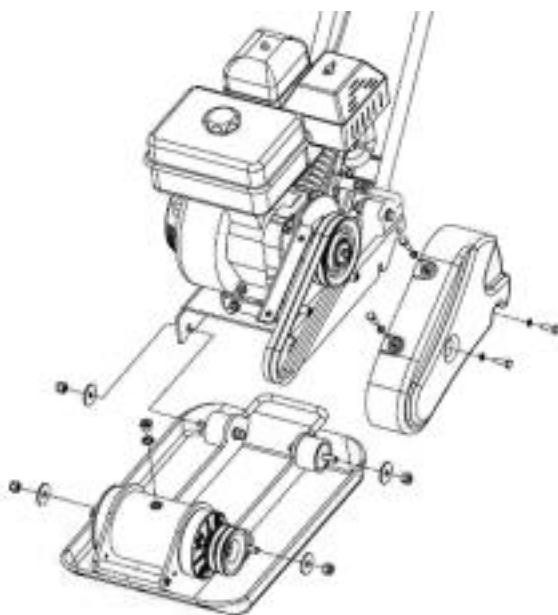

- 8.49 Remove the pipe plug for the top of the exciter housing.
- 8.50 Place a suitable container underneath the machine.

- 8.51 With assistance, tilt the housing upside down to allow the oil to drain.

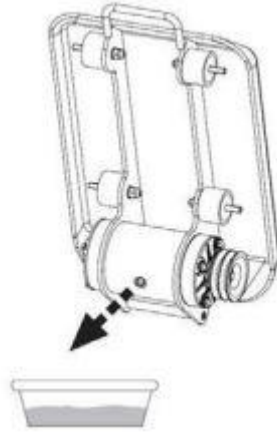

- 8.52 Examine the oil to check for metal chips as a precaution.
- 8.53 Return the housing to an upright position.
- 8.54 Refill the exciter with the correct amount of oil.  
**DO NOT** overfill as overfilling can cause the excess oil to leak out of the breather. The breather is a hole drilled through the output shaft of the agitator.

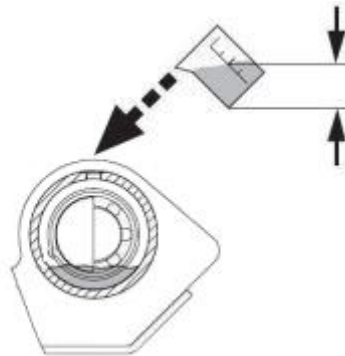

- 8.55 Once the oil is at the correct level, apply pipe sealant to the pipe plug and reinstall into the top of the exciter housing.
- 8.56 Reinstall the deck, V-belt(s) and belt guard.

## CLEANING

- 8.57 **DO NOT** use a pressure washer or hose pipe to clean the machine. Water could penetrate the engine and cause failure.
- 8.58 Use a brush to remove large pieces of debris then wipe over with a moist cloth.
- 8.59 Use a silicone based grease to lubricate moving parts.
- 8.60 **DO NOT** use any solvent based cleaning products to clean the machine. This could damage plastic components.

## 9. TRANSPORTATION & STORAGE



### CAUTION

**ALWAYS** allow the machine to cool completely before storage or transportation.

### TRANSPORT

- 9.0 Drain the fuel tank using a siphon or similar fuel retrieval device.
- 9.1 Store the fuel in a suitable fuel container for transport.
- 9.2 Allow the engine to cool completely.
- 9.3 Ensure the fuel tap and engine switch are in the off position.
- 9.4 Secure the machine upright in the vehicle so it cannot move during transportation.
- 9.5 Fuel and its vapours are flammable so keep away from possible sources of ignition.

### STORAGE



### NOTE

If the machine is to be stored for periods of 30 days or more, then it is essential to prepare the machine for storage correctly. Failure to do so could result in issues making the machine difficult to start or cause poor running.

- 9.6 Drain the fuel tank using a siphon or similar fuel retrieval device, into a suitable fuel container.
- 9.7 Run the engine under no load until the machine stops, to remove any remaining fuel from the carburetor and fuel lines.
- 9.8 Allow the engine to cool completely.
- 9.9 Drain the engine oil from the engine following the procedure laid out in the maintenance section of this manual and refill with fresh engine oil.
- 9.10 Clean the area around the spark plug and remove the spark plug following the procedure laid out in the maintenance section of this manual.
- 9.11 Pour a teaspoon of fresh engine oil down the spark plug hole into the cylinder bore.
- 9.12 Gently pull the recoil start handle 4 to 5 times to coat the cylinder wall with a coating of fresh engine oil.
- 9.13 Refit the spark plug but leave the spark plug HT lead cap removed.
- 9.14 Clean the machine following the cleaning procedure as laid out in the maintenance section of this manual.
- 9.15 Check the tightness of all nuts, bolts and screws.
- 9.16 Store upright, in a cool dry place away from extremes of temperature change and away from any possible sources of ignition



## 10. TROUBLESHOOTING

Problem	Possible Cause	Possible Solution
Engine fails to start	Spark plug HT lead cap disconnected	Re-attach spark plug HT lead cap
	Out of fuel or stale fuel	Fill with clean fresh fuel
	Throttle control lever not in correct starting position	Move throttle control lever to start position
	Choke not in the ON position	Move choke to the ON position
	Blocked fuel line	Clean fuel line
	Fouled spark plug	Clean, adjust gap
	Engine flooding	Wait a few minutes before starting, do not re-prime
Engine runs erratically	Spark plug wire loose	Connect and tighten spark plug wire
	Machine running on choke	Move choke lever to off position
	Blocked fuel line or stale fuel	Clean fuel line and refill with fresh fuel
	Fuel filler cap vent plugged	Clear vent
	Water or dirt in fuel system	Drain and clean fuel tank, refill with fresh fuel
	Dirty air filter	Clean or replace air filter
Engine overheats	Engine oil level low	Fill oil to correct level
	Dirty air filter	Clean or replace air filter
	Airflow restricted	Remove blower housing and clean
Engine will not stop when throttle is positioned at stop	Debris interfering with throttle linkage	Clean and remove debris
Compactor is difficult to control when in operation	Engine speed too high	Set the throttle lever at lower speed

## 11. SPECIFICATION

	<b>HYCP5030</b>	<b>HYCP6570</b>	<b>HYCP9070</b>
<b>Engine Size – cc</b>	78.5	196	196
<b>Engine Type</b>	Hyundai 4 Stroke Single Cylinder OHV		
<b>Fuel Type</b>	Unleaded Petrol		
<b>Oil Type</b>	SAE 30 or SAE15W40 Engine Oil		
<b>Plate Size (LxW) - mm</b>	490 x 320	530 x 370	540 x 420
<b>Centrifugal Force – N</b>	8200	11000	13000
<b>Exciter Speed (VPM)</b>	5900	5500	5500
<b>Compaction Depth – mm</b>	150	250	300
<b>Exciter Oil Type</b>	SAE30 or 15W40		
<b>Exciter Oil Capacity</b>	120ml	150ml	150ml
<b>Weight – Kg</b>	46.5	58	78

## 12. DECLARATION OF CONFORMITY

- 12.0 Genpower confirms that this Hyundai product conforms to the following CE Directives;  
2006/42/EC Machinery Directive  
2004/108/EC EMC Directive  
2000/14/EC Amended by 2005/88/EC Noise Emissions Directive  
97/68/EC 2010/26/EC NRMM Emissions Directive

### EC DECLARATION OF CONFORMITY

The undersigned. As authorised by: **Genpower Ltd**  
Declares that the following equipment manufactured under licence by Hyundai Korea  
Conforms to the Directive:-  
**2000/14/EC (as amended)**

Of the European Parliament and of the council on the approximation of the laws of the Member States relating to the noise emission in the environment by equipment for the use outdoors.

Equipment Category: **Compaction Machinery**

Product Name/Model: **HYCP5030  
HYCP6570  
HYCP9070**

Type/Serial No: **Petrol Driven Compactor Plate**

Net installed power: **HYCP5030: 78.5  
HYCP6570:196cc  
HYCP9070: 196cc**

The technical documentation is kept by: **Roland Llewellyn, Genpower Ltd  
Isaac Way, Pembroke Dock,  
Pembrokeshire, SA72 4RW.**

The conformity assessment procedure followed was in accordance with annex V of the Directive.

Notified Body: **TÜV SUD Product Service GmbH  
Zertifizierstelle, Ridlerstrasse 65  
80339 Munchen, Germany  
Certification n° Z1A 16 01 92113 007**

Measured Sound Power Level: **HYCP5030 : 91dB  
HYCP6570 : 91dB  
HYCP9070 : 91dB**

Guaranteed Sound Power Level: **HYCP5030 : 104dB  
HYCP6570 : 106dB  
HYCP9070 : 108dB**

A copy of this certificate has been submitted to the European Commission and the EU Member State United Kingdom.

Place of Declaration: **Pembroke Dock, SA73 4RW**

Date: **26/01/2016**

Signed by: **Roland Llewellyn**



Position in Company: **Managing Director**

Name and address of manufacturer or Authorised representative:

**Genpower Ltd  
Isaac Way, Pembroke Dock,  
Pembrokeshire, SA72 4RW**

## 13. RECYCLING & PRODUCT DISPOSAL

- 13.0 We do not offer a take back scheme for the recovery of Waste Electrical Electronic Equipment (WEEE) & Batteries.  
Instead the responsibility to dispose of WEEE and or batteries is passed on to you by us.  
So when it becomes necessary to dispose of your machine you must take it to your Local Civic Amenity Site.  
For further information, please contact your Local Authority for disposal advice.
- 13.1 You MUST make sure that all unused oil and fuel is disposed of correctly either beforehand or at your Local Amenity Site.  
Under NO circumstances must any fuel or oil be put down any drains.
- 13.2 Certain products contain WEEE waste which should not be disposed of in your domestic waste.
- 13.3 You MUST recycle WEEE in accordance with your Local Authority or Recycling Centre.
- 13.4 Certain products contain batteries which should not be disposed of in your domestic waste.
- 13.5 You MUST recycle batteries in accordance with your Local Authority or Recycling Centre.
- 13.6 Unwanted packaging and materials should be stored and taken to a recycling centre so it can be disposed of in a manner which is compatible with the environment.
- 13.7 The following symbol means you should 'Reduce – Reuse - Recycle'.
- 13.8 We are a member of VALPAK National Compliance Scheme and our registration number is RM08660.
- 13.9 For further information about disposal, please contact your Local Authority.
- 13.10 You can also get more advice and guidance about recycling at the following website <http://www.recycle-more.co.uk>
- 13.11 Should you pass this product on to another user either sold or loaned, you MUST pass on this user manual.  
This will make sure that all other users can use and maintain this machine safely.

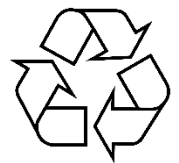

## 14. CONTACT DETAILS

14.0	ADDRESS	Genpower Ltd, Isaac Way, London Road, Pembroke Dock, Pembrokeshire. SA72 4RW. UK.
14.1	TELEPHONE	+44 (0) 1646 687880
14.2	SUPPORT	<a href="mailto:aftersales@hyundaipowerproducts.co.uk">aftersales@hyundaipowerproducts.co.uk</a>
14.3	WEBSITE	<a href="http://www.hyundaipowerproducts.co.uk">www.hyundaipowerproducts.co.uk</a>

## 15. WARRANTY

- 15.0 Proof of purchase will be required before you make a warranty claim. Full warranty terms and conditions can be found on the HYUNDAI POWER PRODUCTS website:  
[www.hyundaipowerproducts.co.uk](http://www.hyundaipowerproducts.co.uk)

## 16. MANUAL UPDATES

- 16.0 Our manuals are constantly being reviewed and updated. However if you find an error, omission or something you find unclear, please contact your dealer for assistance.
- 16.1 Our latest manuals are also placed online.





# **HYUNDAI**

**POWER PRODUCTS**

**Importer:**

**GENPOWER LTD**

**Isaac Way, London Road**

**Pembroke Dock, UNITED KINGDOM, SA72 4RW**

**T: +44 (0) 1646 687 880 F: +44 (0) 1646 686 198**

**E: [info@hyundaipowerproducts.co.uk](mailto:info@hyundaipowerproducts.co.uk)**

**[www.hyundaipowerproducts.co.uk](http://www.hyundaipowerproducts.co.uk)**

**Imported/Distributed by GENPOWER LTD for The United Kingdom & Ireland**

**Licensed by Hyundai Corporation, Korea**