

HYUNDAI
POWER PRODUCTS

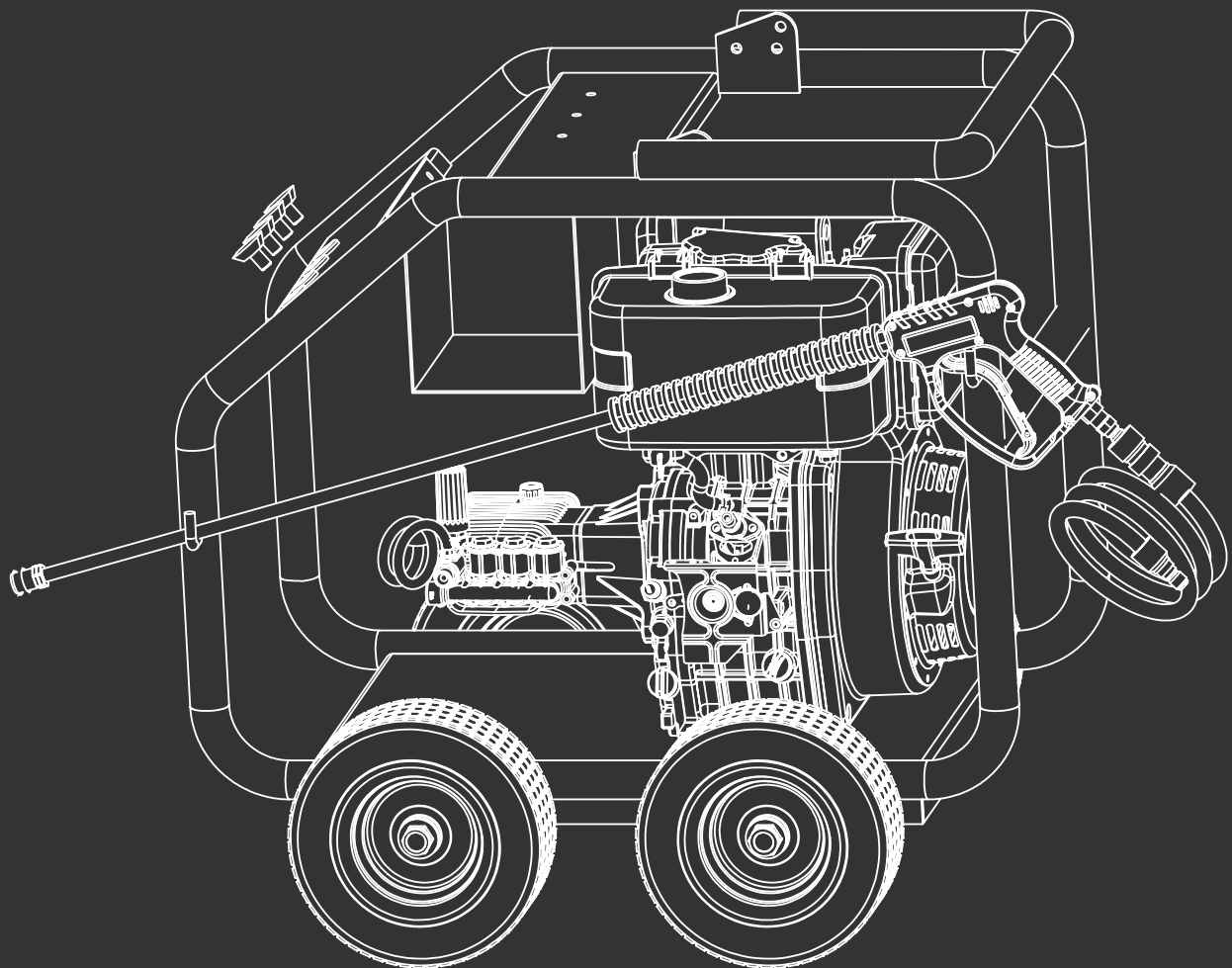

DIESEL PRESSURE WASHER HYW4000DE

User Manual



CONTENTS

1. SAFETY	3 - 5
2. UNPACKNG & ASSEMBLY	6
3. PRE-OPERATION CHECKS	7-8
4. HOW TO START YOUR PRESSURE WASHER	9-12
5. HOW TO STOP YOUR PRESSURE WASHER	12 - 13
6. QUICK RELEASE NOZZLES	13 - 14
7. USAGE TIPS	14 - 15
8. TROUBLESHOOTING	16-17
9. WINTER STORAGE	18
10. MAINTENANCE	19
11. SPECIFICATION	20
12. CONTACT DETAILS	20
13. DECLARATION of CONFORMITY	21

1. SAFETY.  

1.1. The operator of the machine;

1.1.1. Is responsible for and has a duty of care in making sure that the machine is operated safely and in accordance with the instructions in this user manual.

1.1.2. Should never leave it in a condition which would allow an untrained or unauthorised person/s to operate this machine.

1.1.2.1. Should take care and show due diligence for the safety of and with regard to those around whilst using the machine, to include but not limited to;













1.1.2.1.1. Elderly, children, pets, livestock and property.

1.2. Some or all of the following PPE, Warning Signs and symbols may appear throughout this manual and you must adhere to their warning/s. Failure to do so may result in personal injury.

Personal Protective clothing (PPE)



Warning Signs and Symbols – FOLLOW safety messages to avoid or reduce risk of injury or death.

 DANGER DANGER - indicates a hazard which if not avoided could result in serious injury or death.	 WARNING WARNING - indicates a hazard which if not avoided could result in serious injury or death.	 CAUTION CAUTION - indicates a hazard which if not avoided might result in minor or moderate injury.	 NOTE NOTE - indicates a situation that could easily result in equipment damage.	 READ MANUAL
 EXPLOSION	 FIRE	 ELECTRIC SHOCK	 KICKBACK	
 HOT SURFACE	 TOXIC FUMES	 SLIPPERY	 MOVING PARTS	

1.3. Carbon monoxide.



- 1.3.1. Carbon monoxide is a colourless and odourless gas. Inhaling this gas can cause death as well as serious long term health problems such as brain damage.
- 1.3.2. The symptoms of Carbon monoxide poisoning can include but not limited to the following;
 - 1.3.2.1. Headaches, Dizziness, Nausea, Breathlessness, Collapsing or Loss of consciousness.
 - 1.3.2.2. Carbon monoxide symptoms are similar to flu, food poisoning, viral infections and simply tiredness. It is quite common for people to mistake this very dangerous poisoning for something else.
- 1.3.3. To avoid Carbon monoxide poisoning **DO NOT** Use Petrol/Diesel powered equipment inside a home, garage, tent, camper van, mobile home, caravan or boat. The list is not exhaustive if you are in any doubt contact your dealer.
- 1.3.4. If you think you or someone around you has been affected by carbon monoxide poisoning;
 - 1.3.4.1. Get fresh air immediately, by opening doors and windows, turning off the machine and leaving the affected area.
 - 1.3.4.2. See your doctor immediately or go to hospital - let them know that you suspect carbon monoxide poisoning.
- 1.3.5. **DO NOT** use in an enclosed area or a moving vehicle.

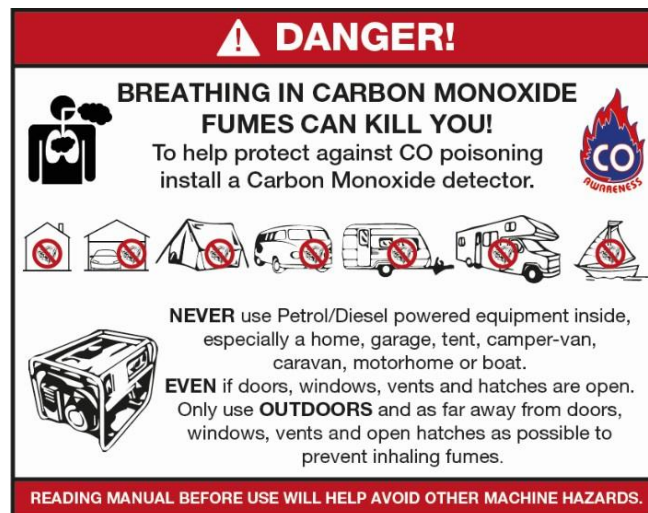

1.4. General fuel safety.



- 1.4.1. Fuel Safety additional information can be obtained from the Health and Safety Executive.
- 1.4.2.  **CAUTION** All fuels are flammable.
- 1.4.3. Keep away from all ignition sources i.e. heaters, lamps, sparks from grinding or welding.
- 1.4.4. Hot work on tanks that have contained fuel is extremely dangerous and should not be carried out.
- 1.4.5. Keep work area clean and tidy.
- 1.4.6. Clean up all spills promptly using correct methods i.e. absorbent granules and a lidded bin.
- 1.4.7. Dispose of waste fuels correctly.



TOXIC FUMES

1.5. Diesel safety.

1.5.1. Always fuel and defuel in well-ventilated area.

1.5.2. Always wear correct, suitable and fit for purpose Personal Protective Equipment (PPE), suggested items are as follows, but are not limited too.



1.5.3. Hand protection.



1.5.4. Protective clothing.



1.5.5. Respiratory protective equipment should be used when in an unventilated area.

1.5.6. When defueling always use a propriety fuel retriever.

1.5.7. Always carry fuel in the correct and clearly marked container.

1.6. Battery safety

1.6.6. Batteries present a risk if they become damage by the possible leaking of electrolyte. This electrolyte is an acid and can cause serious injuries. Care should be taken when working on or near them.

1.6.1.1. Should you come into contact with acid you should;

1.6.1.2. Remove all clothing contaminated with acid.

1.6.1.3. Get medical assistance as soon as possible.

1.6.1.4. Use fresh running water to wash off excess acid, continue this until medical assistance arrives.

1.6.1.5. If acid come into contact with Eyes the acid needs to be immediatly washed away. Make sure that you do not wash the acid to another part of the face or body.

1.6.1.6. Gasses from charging batteries are highly flammable and great care should be taken to charge in well ventilated areas.



Figure 2

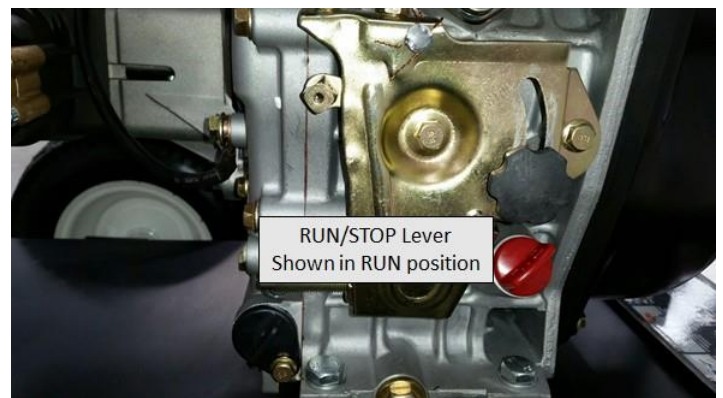

Figure 4

3. UNPACKING & ASSEMBLY

Unpack your pressure washer and make sure the following items are present:

- Hose.
- Gun/lance.
- Lance holder.
- Nozzles
- Detergent hose with filter.
- Wheels and fixings pack.
- Handles (x3) and fixings.
- Garden hose connector.

Contact your dealer immediately if any parts are missing or damaged.

Assembly. (Some models come pre-assembled).

Attaching the wheels .

1. Push the wheels over the axle, then secure in place using the provided flat washer and nyloc nut.
2. Repeat process for each of the four wheels.

NOTE: DO NOT overtighten the nuts as the wheels must be free to rotate.

Attaching the handles.

4. Bolt the two side and one end handles using supplied nuts and bolts.
5. Locate side handles and line up bolts holes. Push bolts through holes in frame then handle. Once the bolt is through use the supplied washer, spring washer and nut to secure the handle.
6. Locate end handle and follow similar procedure as 5 above.



Figure 5

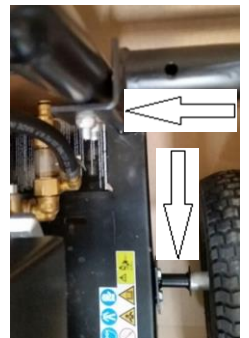



Figure 6



4. PRE-OPERATION CHECKS

Follow the checklist below before using the machine each time.

1. Check to ensure the engine oil is at the correct level. Use SAE 15W40 - API CH-4/CF/SJ/SL diesel engine oil or higher grade.
2. Make sure that all connection, nuts/bolts etc are tight and will not vibrate loose.
3. Add fuel to the diesel tank - regular diesel fuel.
4. Connect and tighten the garden hose to the garden hose connector.
5. Water must be turned on prior to starting the washer. Always pull the spray trigger to prevent pressure build up and ensure water is moving through the hoses and out of the nozzle without any leaks before starting the unit.
5. Review the safety guidelines in the manual prior to starting the unit.
6. If you have any issues operating the pressure washer, contact your dealer.

 WARNING	
 oil	Always check the level of the engine and pump oil prior to starting the washer.
<ul style="list-style-type: none">• Failure to do so could cause the engine and pump to seize if the oil is low or empty.	

Connect hose and water supply to pump before starting.

 WARNING	
	DO NOT start your pressure washer without the water supply turned on.
<ul style="list-style-type: none">• Failure to do so will result in damaging the pump from overheating and voiding the warranty.	

Checking the engine oil level.

1. Turn the oil filler cap/dipstick anti-clockwise and remove it from the oil filler tube, wipe the dipstick with a clean cloth.
2. Insert the oil filler cap/dipstick back into the oil filler tube and then remove it again. DO NOT screw it in when doing this.
3. If the oil is low fill the engine oil sump to the edge of the oil filler hole.
 - We recommend the use of SAE30 - API CH-4/CF/SJ/SL diesel engine oil or higher grade oil in this pressure washer pump.
4. Replace the oil filler cap.

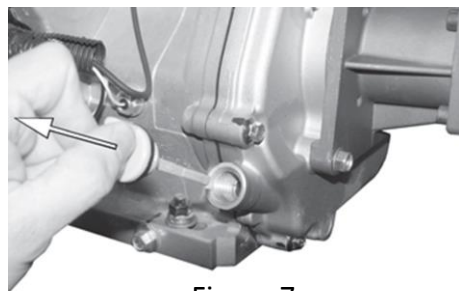

Figure 7

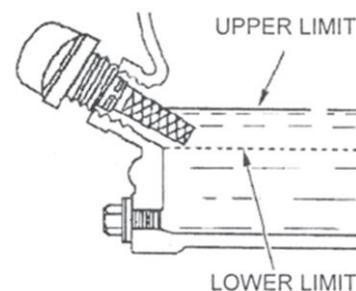

Figure 8

NOTE: Running the engine with insufficient oil can cause engine damage.

Checking the fuel level.

1. To check the fuel level open the fuel tank cap.
2. Just inside the fuel tank is a fuel strainer, check this filter periodically and remove any contaminants which may have accumulated.
3. Refuel in a well-ventilated area before starting the engine.
If the engine has been running, allow it to cool. Refuel carefully to avoid spilling fuel. **DO NOT** fill above the fuel strainer shoulder.
4. After refueling, replace and tighten the fuel tank cap securely.

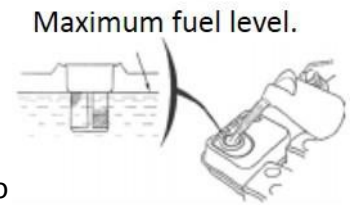

Figure 9

Note: For any further information please use the engine manual for reference.

⚠ WARNING

Always refuel in a well ventilated area away from any heat sources.
Allow the unit to cool down before refuelling.
DO NOT leave fuel within the reach of children.

Pressure regulator.

When supplied the pressure regulator may be set to minimum.

Turn the pressure regulator on the pump fully clockwise to allow water pressure to build up when the pressure washer is running.

You can reduce the pressure to the desired level to suit the work application



Figure 10

Pump oil.

The pump is sealed and should not require attention except when unit is serviced.

Pressure washer terminology.

PSI = Pounds per square inch, the unit of measurement for water pressure.

GPM = Gallons per minute.

Bypass mode.

In bypass mode, the pump recirculates the water because the trigger of the spray gun is not being pulled. If unit is left in bypass mode for more than two minutes, the water temperature will rise to a dangerous level and could damage internal components of the pump.

NOTE: Any damage to pump due to these causes will not be covered under warranty.

Thermal Relief Valve.

In an effort to prevent extreme damage, pumps are equipped with a thermal relief valve. This valve will open when the temperature inside the pump rises too high. This valve will then release a gush of water in an effort to lower the temperature inside the pump. Immediately after this occurs, the valve will close.

Chemical Injection System.

Mixes cleaners or cleaning solvents with the pressurised water to improve cleaning effectiveness.

5. HOW TO START YOUR PRESSURE WASHER

To start your pressure washer for the first time, follow these step-by-step instructions. This starting information also applies if you have let the pressure washer sit idle for at least a day.

1. Place the pressure washer near an outside water source capable of supplying water at a flow rate greater than 14.4 litres per minute and no less than 20 PSI at pressure washer. DO NOT siphon supply water.
2. Make sure unit is in a level position.
3. Connect garden hose to water inlet on pressure washer pump.

 NOTE
DO NOT run the pump without the water supply connected and turned on.
• Damage to the equipment resulting from failure to follow this instruction will void the warranty.

4. Attach the wand extension to spray gun. Tighten by hand, DO NOT overtighten.

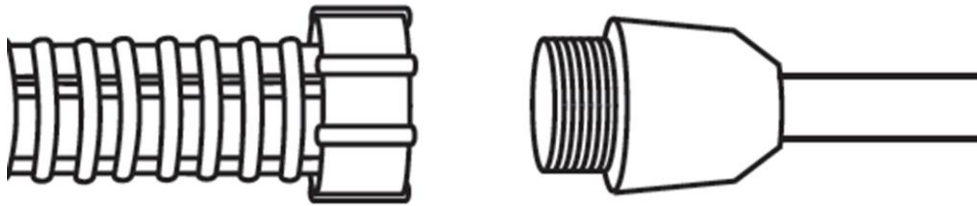

FIGURE 11

5. Choose desired nozzle, pull back the nozzle extension collar, insert nozzle and release collar. Tug on the nozzle to make sure it is securely in place. See nozzle selection section.

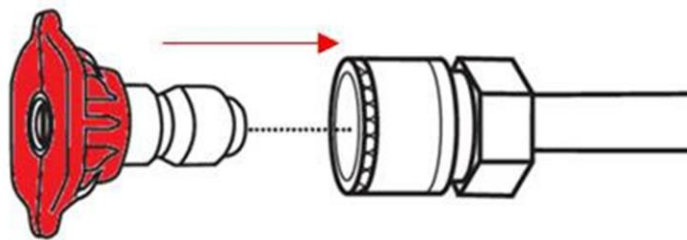

Figure 12

6. Uncoil the high pressure hose and attach the quick connect end of hose to base of the spray gun.

Pull down on the collar of quick connect, slide onto spray gun and let go of collar. Tug on the hose to be sure of a tight connection. Some models may use a threaded hose connector.

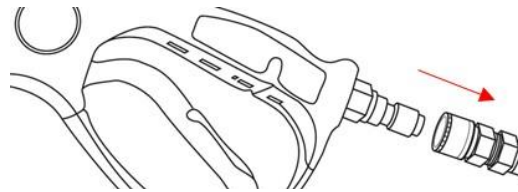

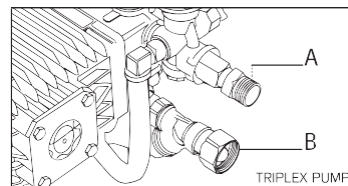
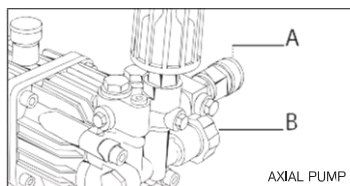

Figure 13

 WARNING	
	The high pressure stream of water that this equipment produces can cut through skin and its underlying tissues, leading to serious injury and possible amputation.
<ul style="list-style-type: none">• NEVER connect a high pressure hose to the nozzle extension.• Keep the high pressure hose connected to pump and spray gun while system is pressurised.• Always be certain the spray gun, nozzles and accessories are correctly attached.	

7. Similarly, attach the other end of the high pressure hose to the high pressure outlet (A) on the pump. Pull down on the collar of the quick connect, slide onto the pump and let go of the collar. Pull on hose to be sure of tight connection.

*Some models may use a threaded hose connector.



8. Point the gun in a safe direction, turn the water supply on, then and squeeze the trigger to purge the pump of air and debris. Do this for at least 30 seconds.

9. Do a visual check of all connections to make sure there are no leaks or loose connections.

IMPORTANT: If drawing water from a barrel, you should take the water from the bottom of the barrel. Use ONLY cold water (less than 38°C/100°F).

10. Connect the garden hose to the water inlet tighten by hand.

11. To **start the machine by recoil**, turn the ignition switch to the ON position. (Figure 1 item 17.)



Check to make sure fuel valve is in the ON position (Figure 2). Unscrew the knob, and move the RUN/STOP (Figure 4) lever to the down position (Figure 3).

Gently pull recoil several times (Figure 1 item 16) until you cannot pull it anymore. With both hands take a firm grip of recoil starter and pull the whole rope rapidly with both hands.



12. Once the machine is running release water pressure by squeezing the trigger on the gun.



13. For **electric start** follow instructions from 1 to 10 & 12.



14. Unscrew the knob, and move the RUN/STOP lever to the down position. Turn the key in a clockwise direction (against spring tension), once started release the key.



 WARNING	
	<p>A running engine gives off carbon monoxide, an odourless, colourless and poisonous gas. Breathing carbon monoxide can cause headache, fatigue, dizziness, vomiting, confusion, seizures, nausea, fainting and/or death.</p>
<ul style="list-style-type: none"> • Operate the pressure washer ONLY outdoors. • Keep exhaust gas from entering a confined area through windows, doors, ventilation intakes, or other openings. • DO NOT start or run the engine indoors or in an enclosed area, even if windows and doors are open. 	

IMPORTANT: Before starting the pressure washer, make sure you are wearing adequate and safe eye protection.

 WARNING	
	<p>Risk of eye injury. Spray can splash back or propel objects.</p>
<ul style="list-style-type: none"> • Always wear safety goggles when using this equipment or in vicinity of where equipment is in use. • Before starting the pressure washer, be sure you are wearing appropriate eye protection. 	

 WARNING	
	<p>Starter cord kickback (rapid retraction) can result in bodily injury. Kickback can pull hand and arm toward the engine faster than you can let it go. Broken bones, fractures, bruises, or sprains could result.</p>
<ul style="list-style-type: none"> • NEVER pull the starter cord without first relieving spray gun pressure. • When starting the engine, pull the cord slowly until resistance is felt and then pull rapidly to avoid kickback. • After each starting attempt, where the engine fails to run, always point the spray gun in a safe direction and squeeze the spray gun trigger to release high pressure. • Firmly grasp the spray gun with both hands when using high pressure spray to avoid injury when the spray gun kicks back. 	



 WARNING	
	<p>The high pressure stream of water that this equipment produces can cut through skin and its underlying tissues, leading to serious injury and possible amputation.</p> <p>The spray gun traps high water pressure, even when engine is stopped and water is disconnected, this high pressure if not released correctly can cause injury.</p>
<ul style="list-style-type: none"> • DO NOT allow children to operate pressure washer. • NEVER repair high pressure hose. Replace it. • NEVER repair leaking connections with sealant of any kind. Replace o-ring or seal. • NEVER connect the high pressure hose to nozzle extension. • Keep the high pressure hose connected to the pump and the spray gun while the system is pressurised. • ALWAYS point spray gun in a safe direction and squeeze the spray gun trigger to release high pressure, every time you stop engine. • NEVER aim spray gun at people, animals or plants. • DO NOT secure the spray gun in open position. • DO NOT leave spray gun unattended while the machine is running. • NEVER use a spray gun which does not have a trigger guard in place and in working order. • ALWAYS be certain the spray gun, nozzles and accessories are correctly attached. 	

 WARNING	
 	<p>Contact with the exhaust area can result in serious burns.</p> <p>Exhaust heat/gases can ignite combustible structures or damage fuel tank causing a fire.</p>
<ul style="list-style-type: none"> • DO NOT touch hot parts and AVOID hot exhaust gases. • Allow equipment to cool before touching. • Keep at least 1.5m (5 feet) of clearance on all sides of pressure washer including overhead. 	

6. HOW TO SHUT DOWN YOUR PRESSURE WASHER

1. Release the spray gun trigger and let the engine idle down.
2. Turn the ignition switch to the OFF position (Figure 1 item 16).
3. Release the locking knob on the RUN/STOP lever (Figure 4) and move it up to the STOP position
3. ALWAYS point the spray gun in a safe direction, squeeze the trigger to release retained high water pressure.

IMPORTANT: The spray gun traps high water pressure, even when engine is stopped and water is disconnected. Couplings will not release if under pressure.

 WARNING	
	<p>The high pressure stream of water that this equipment produces can cut through skin and its underlying tissues, leading to serious injury and possible amputation.</p> <p>The spray gun traps high water pressure, even when engine is stopped and water is disconnected, which can cause injury.</p>
<p>Keep the high pressure hose connected to pump and spray gun while the system is pressurised.</p> <ul style="list-style-type: none"> • ALWAYS point the spray gun in safe direction and squeeze the spray gun trigger to release the high pressure, every time you stop engine. 	

7. QUICK RELEASE NOZZLES

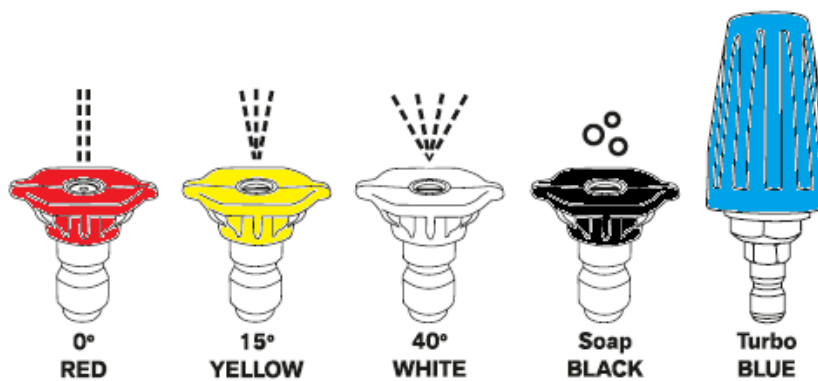



Figure 14

The quick-release on the lance allows you to switch between five different quick-release nozzles.

The nozzles can be changed while the pressure washer is running once spray the gun trigger safety lock is engaged.

The different nozzles vary the spray pattern as shown above.

 WARNING	
	<p>The high pressure stream of water that this equipment produces can cut through skin and its underlying tissues, leading to serious injury and possible amputation</p>
<ul style="list-style-type: none"> • NEVER change nozzles without the trigger safety lock engaged on the spray gun. • DO NOT twist nozzles whilst spraying. 	

Follow these instructions to change the nozzles:

1. Pull back the collar on the quick connect and pull current nozzle off. Store the nozzles in holder provided on the handle. Storing nozzles in the designated holder will help prevent debris clogging the tip.
2. Select desired nozzle:
 - For a gentle rinse, select white 40° nozzle.
 - To scour surface, select red 0° or yellow 15° nozzle.
 - To apply detergent, select black nozzle.
3. Pull back on the collar, insert the new nozzle and release the collar. Tug on the nozzle to make sure it is securely in place

8. USAGE TIPS

- For most effective cleaning, keep the nozzle away from cleaning surface at a distance of between 8 & 24 inches (203mm & 610mm).
- If you let a high pressure nozzle get too close to the surface being cleaned it may be damaged.

To apply detergent, follow these steps:

1. Fit the black soap nozzle.
2. Prepare the detergent solution as required by job.
3. Place the small filter end of detergent siphoning tube into detergent container.

NOTE

Make sure the filter is fully submerged in detergent while applying detergent.

This washer will only draw soap with the black soaper nozzles. The the white, red and yellow nozzle WILL NOT draw soap.

4. Make sure the black nozzle is installed.
5. Make sure the garden hose is connected to the water inlet. Check that the high pressure hose is connected to the spray gun and pump. Turn on the water.

 CAUTION
You must attach all hoses before you start the engine.
<ul style="list-style-type: none">• Starting the engine without all the hoses connected and without the water turned ON will damage the pump. Damage to the equipment resulting from failure to follow this instruction will void the warranty.

6. Start the engine following instructions in the 'Starting Your Washer' section.
7. Apply detergent to surface, using long, even and overlapping strokes.

8. Allow detergent to "soak in" for 5 minutes before washing and rinsing. Re apply as needed to prevent the surface from drying. DO NOT allow detergent to dry on.

IMPORTANT: You must flush the detergent siphoning system after each use by placing the filter into a bucket of clean water, then run the pressure washer in low pressure for 1-2 minutes.

 CAUTION
Chemicals can cause bodily injury and/or property damage.
<ul style="list-style-type: none">• NEVER use caustic liquid with pressure washer.• Use ONLY pressure washer safe detergent/soaps. Follow all manufacturers instructions.

9. TROUBLESHOOTING

If you have checked all the possible cause listed and you are still experiencing the problem, contact your dealer.

Problem	Cause	Correction
Unit has following problems: Failure to produce pressure, erratic pressure, chattering, loss of pressure, low water volume.	<ol style="list-style-type: none"> 1. Low pressure spray tip installed. 2. Water inlet is blocked. 3. Inadequate water supply. 4. Inlet hose is kinked or leaking. 5. Clogged inlet hose screen. 6. Water supply is over 100°F (38°C). 7. High pressure hose is blocked or leaks. 8. Spray gun leaks. 9. Spray tip is obstructed. 10. Pump is faulty. 	<ol style="list-style-type: none"> 1. Replace with high pressure spray tip. 2. Clear inlet. 3. Provide adequate water flow. 4. Straighten or repair inlet hose, patch 5. Check and clean inlet hose screen. 6. Provide cooler water supply. 7. Clear blocks in outlet hose. 8. Replace spray gun. 9. Clean spray tip. 10. Contact your dealer
Detergent fails to mix with spray.	<ol style="list-style-type: none"> 1. Detergent siphoning tube is not submerged. 2. Detergent siphoning tube/ filter is clogged or cracked. 3. High pressure spray tip installed. 	<ol style="list-style-type: none"> 1. Insert detergent siphoning tube into detergent. 2. Clean or replace filter/ detergent siphoning tube. 3. Replace with low pressure spray tip.
Engine lacks power.	<ol style="list-style-type: none"> 1. Dirty air filter. 	<ol style="list-style-type: none"> 1. Replace air filter.
Engine will not start.	<ol style="list-style-type: none"> 1. Throttle lever on/off switch in OFF position. 2. No fuel in engine. 3. Pressure build up in pump. 	<ol style="list-style-type: none"> 1. Turn throttle lever to ON position. 2. Fill fuel tank or turn on fuel supply. 3. Squeeze trigger on spray lance.
Units with oil alert.	<ol style="list-style-type: none"> 1. Engine not level or engine oil level too low. 	<ol style="list-style-type: none"> 1. Place engine on level surface or fill with SAE 15W40 - API CH-4/CF/SJ/SL diesel engine oil or higher grade

Engine runs well at no load but "bogs" down under full load.	1. Engine speed is too slow.	1. Adjust throttle lever back to full throttle.
Engine will not start; or starts and runs rough.	1. Low oil level. 2. Dirty air cleaner. 3. Out of fuel.	1. Fill to proper level. 2. Clean or replace air cleaner. 3. Fill fuel tank.
Engine shuts down during operation.	1. Out of fuel. 2. Low oil level.	1. Fill fuel tank. 2. Fill with oil, to proper level.
Engine lacks power.	1. Dirty air filter.	1. Replace air filter.

Problem	Cause	Correction
No low pressure detergent delivery	1. Using wrong nozzle. 2. Siphon hose or filter is blocked.	1. Insert black soaper nozzle. 2. Unblock siphon hose.
Unit does not reach required pressure	1. Restricted or insufficient water supply. 2. Unsuitable or worn out nozzle. 3. Regulator set too low.	1. Check supply hose, tap and inlet water filter. It must be connected to water source which provides 14.4 litres per minute and no less than 20 PSI. 2. Replace nozzle. 3. Reset unloader by turning knob (clockwise increases pressure).
Thermal relief valve is open and discharging water from side of pump.	1. Water temperature is too high. 2. Pump has been operating for 3 mins without pulling trigger.	1. Use cool water only. 2. Pull trigger at least 30 seconds every 3 mins.
Leak in the fittings.	1. Water leak in high pressure fittings, hose or gun.	1. Tighten hose fittings, replace hose or gun. If problem continues, contact your dealer.
Pump oil is low.	1. Normal use consumes oil over time.	1. To gauge the oil level, look directly into the sight glass. Oil level should always be at the center dot. DO NOT overfill. Replace with 30W non detergent mineral oil.
Oil is milky color.	1. Seals have worn from use and water has leaked in.	1. Return unit to local dealer to have seals replaced.

10. WINTER STORAGE

 NOTE	
You must protect your unit from freezing temperatures.	
<ul style="list-style-type: none">• Failure to do so will permanently damage your pump and render it inoperable.• Damage caused by the effect of freezing are covered under warranty.	

To protect the unit from freezing temperatures:



1. Use a pump saver to treat the pump. This minimises freeze damage and lubricates pistons and seals. Contact your dealer for a pump saver solution.
2. If pump saver is not available, connect a 1 metre section of garden hose to water inlet adapter. Pour RV-antifreeze (antifreeze without alcohol) into the hose. Pull the recoil handle twice. Disconnect the 1 metre hose.
3. Store the unit in a clean, dry area (heated area preferred).

Long term storage.

If you **DO NOT** plan to use the pressure washer for more than 30 days, you must prepare the engine and pump for long term storage.

Other storage tips.

1. **DO NOT** store fuel from one season to another.
2. Replace fuel container if it starts to rust. Rust and/or dirt in fuel can cause problems if it's used with this unit.
3. Cover the unit with a suitable protective cover that does not retain moisture.
4. Store the unit in a clean and dry area.

 WARNING	
	Storage covers can be flammable.
<ul style="list-style-type: none">• DO NOT place a storage cover over a hot pressure washer.• Let the equipment cool for a sufficient time before placing the cover on the equipment.	

11. MAINTENANCE

Item		FREQUENCY				
		Every time.	1 st month or 20 hours.	Every season or 50 hours.	Every 6 months or 100 hours.	Yearly or every 300 hours.
Engine oil.	Oil level.	Y				
	Replace.		Y		Y	
Pump oil.	Oil level.	Y				
	Replace.		Y		Y	
Air filter.	Check.	Y				
	Clean.			Y*	Y*	
	Replace.					Y*
Valve clearance.	Check/ Adjust.					Y
Fuel tank and filter.	Clean.					Y
Fuel pipeline.	Check					Y
* More often than in schedule if used in dusty conditions.						

NOTES

CAUTION

Only use parts supplied by the manufacturer in order to reduce the risk of damage to the machine.

WARNING

Before servicing make sure that the machine is completely switched off and make sure that there is good ventilation in the area.

ENGINE OIL REPLACEMENT.

Draining the engine oil whilst the engine is still hot ensures that drainage is quick and easy.

Remember to check the drain plug is securely fastened after draining.

NOTE

When disposing of oil containers please do so at a recycling/amenity centre for environmental reasons.

12. SPECIFICATION

Model	HYW4000DE
Battery.	36ah
Engine.	Hyundai D500E, Forced Air- cooled, OHV.
Displacement cc.	498
Power hp/kw.	12hp 9.6kW
Fuel type.	Diesel.
Fuel tank capacity L.	5.5
Start method.	Recoil & Electric.
Maximum engine speed rpm.	3600rpm
Lubrication oil.	SAE 10W/30 or 15W/40 API CH-4/CF/SJ/SL diesel engine oil or higher grade).
Lubrication oil capacity (Litres) Max flow rate	1.75L 900L/hour, 15L/minute
Pump type.	Annovi Reverberi RSV4G40 Triplex Pump
Max pressure	4000psi / 275bar

13. CONTACT DETAILS

Postal address.

Genpower Limited, Isaac Way, Pembroke Dock, Pembrokeshire,
SA72 4RW, UK.

Telephone/Fax contact numbers.

Office +44 (0) 1646 687880

Fax +44 (0) 1646 686198

E-mail contacts.

aftersales@hyundaipowerproducts.co.uk

Web Site.

www.hyundaipowerproducts.co.uk

14. DECLARATION of CONFORMITY

HYUNDAI

POWER PRODUCTS

Importer:

GENPOWER LTD

Isaac Way, London Road

Pembroke Dock, UNITED KINGDOM, SA72 4RW

T: +44 (0) 1646 687 880 F: +44 (0) 1646 686 198

E: info@hyundaipowerproducts.co.uk

www.hyundaipowerproducts.co.uk

Imported/Distributed by GENPOWER LTD for The United Kingdom & Ireland

Licensed by Hyundai Corporation, Korea