

HYUNDAI
POWER PRODUCTS

ARTIFICIAL GRASS SWEEPER/BRUSH HYSW1600E

Instruction Manual

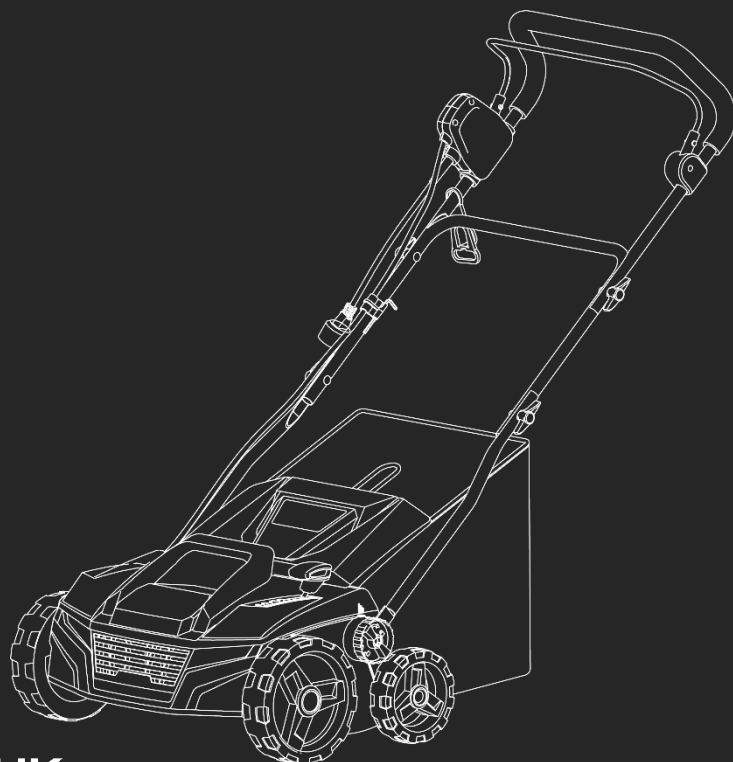

WARNING: Read the instructions carefully before use.

Contents

Introduction.....	3	Maintenance & Care.....	33-36
Safety Information.....	4-13	General Maintenance.....	33
Understand Your Machine.....	4	Storage.....	3
Personal Safety.....	4-5	Cleaning.....	33
Inspect Your Machine.....	5-6	Cleaning/Replacing Brush Cartridge..	34-35
Work Area.....	6	Troubleshooting.....	36
During Use.....	7	Spare Parts.....	37-47
Batteries.....	8	Specifications.....	48
Electricity.....	9	Recycling And Disposal.....	49
Double Insulated Devices.....	9	Declaration Of Conformity.....	50
Vibrations.....	10	Notes.....	51-52
Noise.....	10	Useful Information.....	53
Residual Risks.....	10	Our YouTube Channel.....	53
Intended Use.....	11	Warranty.....	53
Personal Protective Equipment.....	12	Manual Updates.....	53
Symbols On The Machine.....	13	Returning Your Product.....	53
Unboxing.....	14	Leaving A Review.....	53
In The Box.....	15-16	Ordering Spare Parts.....	53
Features.....	17-18	Product Record.....	54
Assembly.....	19-27	Contact Us.....	55
Assembly Overview.....	19		
Attach The Lower Handles.....	19-20		
Attach The Middle Bar.....	21		
Attach The Upper Handle.....	22		
Attach Cable Clip.....	23		
Assemble Collection Basket.....	24		
Attach The Collection Basket.....	25		
Cable Relief Hook.....	26		
Working Depth Adjustment.....	27		
Operation.....	28-32		
Preparing Your Artificial Lawn.....	28		
Working Direction.....	29		
Self Propulsion.....	29		
Sweeping Near Walls or Raised Borders.....	29		
Tips And Tricks For Brushing/Sweeping...	30		
Lawn Striping.....	30		
Before Starting Work.....	31		
Starting.....	31		
Stopping.....	32		

Introduction

Thank You For Purchasing Your HYUNDAI Product

We work very hard to give all of our customers the best possible service. If you have any problems, before leaving negative feedback, please contact us to give us a chance to resolve the issue. We would be delighted if you left us positive feedback! Thank you for purchasing this product.

Important!



WARNING: READ THE INSTRUCTION BOOKLET THOROUGHLY BEFORE USING THE MACHINE. Keep for future reference and pass it on if the machine is loaned or sold to another user.

This manual has been produced by Hyundai Power Products and should be kept with the product. Please read and understand these instructions before you use your product. Failure to do this may result in personal injury or damage to the product.

The safety precautions and warnings are to ensure your safety and protect you from harm or damage to the product.

The information contained in this manual was accurate at the time of production, however HYUNDAI Power Products may make modifications to the product without notification.

Safety Information

Understand Your Machine

- **WARNING!** You must read these instructions carefully before operating the machine. Make sure that you are familiar with the controls and properly operate the machine. You must learn how to stop the machine quickly. If you do not follow the warnings and instructions, it may result in fire and/or serious injury. Make sure to save all warnings and instructions for future reference.
- Read this manual and labels affixed to the machine to understand its limitations and potential hazards.
- Be thoroughly familiar with the controls and their proper operation. Know how to stop the machine and disengage the controls quickly.
- If the unit is to be used by someone other than original purchaser, or is to be loaned, rented, or sold, always provide this manual and any needed safety training before operation. The user can prevent and is responsible for accidents or injuries that may occur to themselves, to other people, or to property.
- Do not force the machine beyond its limits. Use the correct machine for your application.
- Know how to stop the machine quickly in case of emergency. Understand the use of all controls.
- ALL MAINTENANCE other than that listed in this manual, should be carried out by professionally trained and certified personnel.
- When using this machine for the first time and before actual work, you **MUST** learn how to handle the machine from an experienced or skilled person.

Personal Safety

- **WARNING!** Never allow children or people unfamiliar with these instructions to use the product. Local regulations can restrict the minimum age of the operator.
- Keep children, pets, and other people not using the unit away from the work area (at least 15m). Be alert and shut off the unit if anyone enters work area. Keep children under the watchful care of a responsible adult.
- Stay alert, watch what you are doing and use common sense when operating the machine. Never operate the machine when unwell or tired, or if you have taken alcohol, medicine, drugs or any substances which may slow your reflexes and compromise judgment. A moment of inattention while operating the machine may result in serious personal injury.
- Appropriate Personal Protective Equipment (PPE), **MUST** be worn at all times when operating or repairing the machine. Always wear anti-slip and resistant work footwear and long trousers while using the machine. Do not use the machine when barefoot, wearing sandals or similar lightweight footwear. Do not wear chains, bracelets or clothing that is loose fitting or hanging ties or cords. Tie long hair back. Always wear protective earplugs. Loose clothes, jewellery, or long hair can be caught in moving parts. Protect eyes, face, and head from objects that may be thrown from the unit. Always wear safety goggles or safety glasses with side shields when operating.
- Always keep hands and feet away from all moving parts during operation. Moving parts can cut or crush body parts. Always keep hands and feet away from all pinch points.

Safety Information

Personal Safety (Continued)

- Do not touch parts that might be hot from operation. Allow parts to cool before attempting to maintain, adjust, or service.
- Do not overreach. Keep proper footing and balance at all times. This enables better control of the machine in unexpected situations. Extending your body too far can result in a loss of balance and you may fall which will result in injury.
- Never place any part of your body where it would be in danger if movement should occur during assembly, installation, and operation, maintenance, repairing or moving.
- Keep in mind that the operator or user is responsible for accidents, hazards or unexpected events involving the machine that occur to other people or their property. It is the responsibility of the user to assess the potential risk of the area where work is being carried out. The operator or user must take all necessary precautions to ensure their own safety and that of others, especially on slopes or rough, slippery and unstable ground.

Inspect Your Machine

- Check your machine before starting it. Keep guards in place and in working order. Make sure all nuts, bolts, etc., are securely tightened.
- You must check the general condition of the machine before use.
- Never operate the machine when it is in need of repair or is in poor mechanical condition. Replace damaged, missing, or failed parts before using it. Check for fuel leaks. Keep the machine in safe working condition.
- Do not use the machine if the machine's switch does not turn off the machine when running. Any machine that can't be controlled with the switch is dangerous and must be replaced.
- Regularly check to see that keys and adjusting wrenches are removed from the machine area before starting it. A wrench or a key that is left attached to a rotating part of the machine may result in personal injury.
- If the machine should start to vibrate abnormally, stop the machine and check immediately for the cause. Vibration is generally a warning sign of trouble.
- Avoid accidental starting. Be sure the switch is off before transporting the machine or performing any maintenance or service on the unit. Transporting or performing maintenance or service on a machine with its switch on invites accidents.
- Do not tamper with or disable safety systems.
- Only use manufacturer-recommended attachments.
- Before using, always visually inspect to see that the tools are not worn out or damaged. Replace worn out or damaged elements and bolts in set to preserve balance.
- Keep the machine in good operating condition. Operating the machine in poor or questionable condition could result in serious injury.
- Be sure all safety devices are in working order and warning labels are in place. These items are installed for your safety.

Safety Information

Work Area

- You must only work in daylight or with good artificial light in good visibility conditions. Do not work at night, at times of heavy fog, or at any other times when your field of vision might be limited and it would be difficult to gain a clear view of the area.
- Keep people, children and animals away from the working area.
- Operate on flat, level ground.
- DO NOT work on wet ground. If there has been heavy rain on the working site, wait until the ground has dried up.
- Never park the machine in a place with unstable ground which could give way.
- You must be careful near ravines, ditches or embankments.
- Exercise extreme caution when operating on or crossing gravel drives, walks, or roads. Stay alert for hidden hazards or traffic.
- Do not work in the rain, when there is a thunderstorm or lightning risk, at times of strong or gale force winds, or at any other times when the weather conditions might make it unsafe to use this product. If there is bad weather conditions, do not use the machine.
- Make sure you thoroughly inspect the entire work area and remove all objects and anything that could be thrown by the machine or could damage the machine (branches, stones, wire, toys, etc). Attempting to clear the work area whilst using the machine will reduce your concentration and creates a trip hazard. Any liquid spilled on the floor may result in you slipping.
- Find and locate all fixed objects in the ground, such as sprinkler systems, poles, water valves, bases for washing lines etc. Make sure that you check for hidden electrical cables or similar on the surface of the lawn. ALWAYS run the machine around these objects. NEVER run the machine over foreign objects.
- DO NOT operate power tools in explosive atmospheres, such as in the presence of flammable liquids, gases or dust. Power tools may create sparks, which may ignite the dust or fumes.
- This machine is only for outdoor use.

Safety Information

During Use

- Do not operate the machine in confined areas where there may be a risk of crushing the operator between the machine and another object.
- Never attempt to make any adjustments, while the machine is running.
- You must switch off the machine:
 - Before checking or working on the machine.
 - When transporting the machine.
 - Whenever you leave the machine unattended.
 - If the machine starts to vibrate abnormally.
- **WARNING!** If something breaks or an accident happens whilst working, you must turn off the machine immediately and move the machine away to prevent further damage. If an accident happens with injuries or third parties are injured, carry out the first aid measures most suitable for the situation immediately and contact the medical authorities for any necessary health care. Carefully remove any debris that might cause damage or harm persons or animals should it not be seen.
- After striking a foreign object, stop the machine immediately and inspect the machine thoroughly for damage. Repair the damage before continuing.
- Keep extension cord away from moving parts.
- Never operate the machine with damaged guards or without the guard in place.
- Keep hands and feet away from the moving parts at all times especially when switching on the motor.

Safety Information

Batteries (Where Present)

Batteries present a risk if they become damaged by the possible leaking of electrolyte. This electrolyte is an acid and can cause serious burn injuries. Care should be taken when working on or near them. **NOTE:** the electrolyte may be in a liquid or gel form.

Should you come in to contact with electrolyte you should;

- Remove all clothing contaminated with electrolyte. If you cannot remove then saturate them in water.
- Get medical assistance as soon as possible.

You must advise the medical staff of the type of acid.

- Lead/acid battery = dilute sulphuric acid.
- Nickel/cadmium = potassium hydroxide alkali electrolyte.
- Use fresh running water to wash off excess electrolyte, continue this until medical assistance arrives. Make sure that you do not wash the electrolyte to another part of your body or face.
- If electrolyte comes in to contact with Eyes the electrolyte needs to be immediately washed away with large amounts of water. Make sure that you do not wash the electrolyte to another part of your face or body.
- Gasses from charging batteries are highly flammable and great care should be taken to charge in well ventilated areas.



- There is an explosion risk if the battery terminals are short circuited, when connecting/disconnecting ALWAYS exercise great care so that the terminals or battery leads are NOT allowed to touch and cause a spark. ALWAYS use suitable insulated tools.

Electricity (Where Applicable)

DANGER : ELECTRICITY CAN KILL – NEVER WORK ON LIVE / ENERGISED EQUIPMENT.



- Prior to carrying out any maintenance work you MUST identify electrical isolation methods and isolate all electrical supplies.
- Prior to use and with all electrical supplies isolated, you MUST check all electrical cables, plugs and connectors for the following;
 - Are intact and have no signs of damage, to include but not limited to bare wires, chaffing, cuts and loose wiring.
 - If there are any signs of damage, the damaged item MUST be taken out of service until the damage has been repaired by an electrically competent person.
 - All trailing cables should be routed so as not to cause any kind of trip hazard.
 - NEVER work on or near electricity with wet hands, wet clothing and wet gloves.

Safety Information

Electricity (Continued)

- Power tools plug must match the outlet. Never modify the plug in any way. DO NOT use any adapter plugs with earthed (grounded) power tools. Unmodified plugs and matching outlets will reduce risk of electric shock.
- DO NOT expose this power tool to rain or wet conditions. Water entering a power tool will increase the risk of electric shock. DO NOT abuse the power cord. Never use the cord for carrying, pulling or unplugging the power tool. Keep the cord away from heat, oil and sharp edges or moving parts. Damaged or entangled cords increase the risk of electric shock. When operating a power tool, use an extension cord suitable for outdoor use. Use of a cord suitable for outdoor use reduces the risk of electric shock.
- **IMPORTANT:** Make sure that the electric circuit is fused, and that the power, voltage and frequency of the motor is supported by your mains supply. Also, make sure that your power supply is earthed. Connect your machine to earth. Never open the ON/OFF switchbox. However, if it should become necessary to do so, contact a qualified electrician. Make sure that you will never touch live contacts, specifically when you plug or unplug your machine. This machine and its power cord must never get into contact with water.
- Avoid body contact with earthed or grounded surfaces such as pipes, radiators, ranges and refrigerators. There is an increased risk of electric shock if your body is earthed or grounded.
- To prevent electric shock, use only with an extension cord suitable for outdoor use. For additional protection, the installation of a residual current device (RCD) having a rated residual operating current not exceeding 30mA is advisable.
- Before use, check that the extension cord is in good condition. When using an extension cord, make sure to use one heavy enough to carry the current your product will draw. An undersized cord will cause a drop in line voltage resulting in loss of power and overheating.
- Do not allow any part of the machine to make contact with water while it is in operation. If the appliance becomes wet while turned off, wipe dry before starting. Do not touch the appliance or its plug with wet hands or while standing in water. Wearing rubber boots offers some protection.
- Before use, check the supply and extension cord for signs of damage or aging. If the cord becomes damaged during use, disconnect the cord from the supply immediately. If the supply cord is damaged, it must be replaced by the manufacturer or a qualified person in order to avoid a hazard.

Double-Insulated Appliances

In a double-insulated appliance, two systems of insulation are provided instead of grounding. No grounding means that it is already provided on a double-insulated appliance. Servicing a double-insulated appliance requires extreme care and knowledge of the system, and should be performed only by qualified service personnel. Replacement parts for a double-insulated appliance must be identical to the parts they replace.

Safety Information

Vibrations (Where Applicable)

- Prolonged use of hand held (operated) machines will cause the user to feel the effects of/from vibrations. These vibrations can lead to white finger (Raynaud's phenomenon) or carpal tunnel syndrome. This condition reduces the ability of the hand to feel and regulate temperature, causing numbness and heat sensations and may cause nerve damage and circulatory tissue death.
- Not all factors that lead to white finger disease are known, but cold weather, smoking and other diseases that affect blood vessels and blood circulation as well as large and long-lasting impact of shocks are considered factors in the formation of white finger. Note the following to reduce the risk of white finger and carpal tunnel syndrome;
- Wear gloves and keep your hands warm.
- Take regular breaks.
- All of the above precautions may help reduce the risk of white finger disease but not rule out the carpal tunnel syndrome. Long-term and regular users are therefore recommended to observe the condition of your hands and fingers. Seek medical attention immediately if any of the above symptoms should occur.

Noise (Where Applicable)

- The operating noise of the machine can damage your hearing. When wearing protection such as earplugs or ear defenders to protect your hearing. Long-term and regular users are advised to have hearing checked regularly. Be especially vigilant and cautious when wearing ear protection because your ability to hear alarm warnings will be reduced.
- Noise emissions for this equipment is unavoidable. Carry out noisy work at approved times and for certain periods. Limit the working time to a minimum. For your personal protection and protection of people working nearby it is also advisable for them to wear hearing protection.



- See Certificate of Conformity section for Outdoor Noise declaration of conformity.

Residual Risks

Even when tool is used as prescribed it is not possible to eliminate all residual risk factors. The following hazards may arise in connection with the tool's construction and design:

1. Damage to lungs if an effective dust mask is not worn.
2. Damage to hearing if effective hearing protection is not worn.

Health defects resulting from vibration emission if the power tool is being used over longer period of time or not adequately managed and properly maintained.

▲ WARNING! This machine produces an electromagnetic field during operation. This field may under some circumstances interfere with active or passive medical implants. To reduce the risk of serious or fatal injury, we recommend persons with medical implants to consult their physician and the medical implant manufacturer before operating this machine.

Safety Information

Intended Use

The HYSW1600E is an electric sweeper/brush from HYUNDAI. The HYSW1600E has a working width of 380mm and is powered by a 1600W HYUNDAI motor.

This machine is a specifically a pedestrian garden tool, manufactured according to the latest safety requirements. Every precaution is only effective when it's followed exactly.

Intended Use

This machine was designed and manufactured for brushing artificial grass, renewing flattened and matted artificial grass; separating the fibres. It also sweeps garden debris such as leaves and small twigs.

User Types

This machine is intended for use by consumers, i.e. non professional operators. The machine is intended for "DIY" and domestic use only.

Improper Use

Any other usage not in keeping with the above mentioned ones may be hazardous and harm persons and/or damage things. Examples of improper use may include, but are not limited to:

- Use for fine particulate debris i.e dust, sand, small rocks/pebbles
- Transporting people, children or animals on the machine.
- Using the machine to tow or push loads.
- Using the machine for large or heavy debris collection.
- Use of the machine by more than one person.

Safety Information

Personal Protective Equipment

Appropriate Personal Protective Equipment (PPE), MUST be worn at all times when operating or repairing the machine. No protective equipment can ensure 100% protection.

When selecting PPE, make sure it's CE marked and it suits the user in terms of size, fit, etc. If more than one item of PPE is worn at the same time, make sure they can be used together, e.g. wearing safety glasses may disturb the seal of a respirator, causing air leaks.



Hand Protection Must Be Worn

Protective electrically non-conductive gloves are highly recommended when working.



Foot Protection Must Be Worn

Non-skid heavy duty footwear are highly recommended when working.



Hearing Protection Must Be Worn

Suitable safety hearing protection is recommended.



Eye Protection Must Be Worn

Always wear safety glasses/goggles and/or face shields. Everyday eyeglasses have only impact resistant lenses; they are not safety glasses/goggles.



Protective Clothing Must Be Worn

Do not wear loose clothing, gloves, scarfs, neckties or jewellery (rings, wrist watches), which can be caught in moving parts.



Head Protection Must Be Worn

Wear a safety helmet with a safety visor.

















Face Shield Must Be Worn

Wear a face shield to protect your face.

Safety Information

⚠ Symbols On The Machine

We have provided safety messages in this manual and on the machine. This information alerts you to potential hazards that could hurt you or others. Please read these messages carefully. However, we may not have listed all of the possible hazards, you must also use your own judgement.

Symbol	Description	Symbol	Description
	Safety alert – Indicates a precaution, a warning or a danger.		Wear eye and hearing protection. For protection against injury, wear ear defenders and safety goggles.
	Do not expose to rain.		Class II tools symbol.
	Read operator's manual.		Keep bystanders at a safe distance away from the work area.
	The UKCA (UK Conformity Assessed) marking is a UK product marking that is required for goods being placed on the market in Great Britain (England, Wales and Scotland).		This product complies with the European directives and an evaluation method of conformity for these directives was done.
	Danger! Rotating parts – keep hands and feet away from moving parts.		Sharp blades can cut limbs.
	Keep bystanders at a safe distance away from the work area.		Switch off and unplug the device before cleaning or performing maintenance on it.
	This product should not be disposed of in domestic waste. Please contact your local recycling centre for disposal service.		Do not use the machine if the cable is damaged.

Unboxing

⚠ WARNING : Unboxing and assembling the machine should be done on a flat, surface with enough room. Disposal of the packaging should be done in accordance with the local regulations in force.

⚠ WARNING : Some of the packaging material may be harmful to children. Keep out of reach of children.

1. Carefully remove the product from the packaging and examine it for any sign of damage caused during shipping.
2. Lay the contents out and check them. If any part is damaged or missing, you must not use the machine. Contact HYUNDAI POWER PRODUCTS immediately.
3. You must keep the packaging material in case the machine needs to be returned or repaired.
4. Ensure that you have all the accessories and tools you need for assembly and operation including the suitable personal protective equipment.

In The Box

*Not To Scale

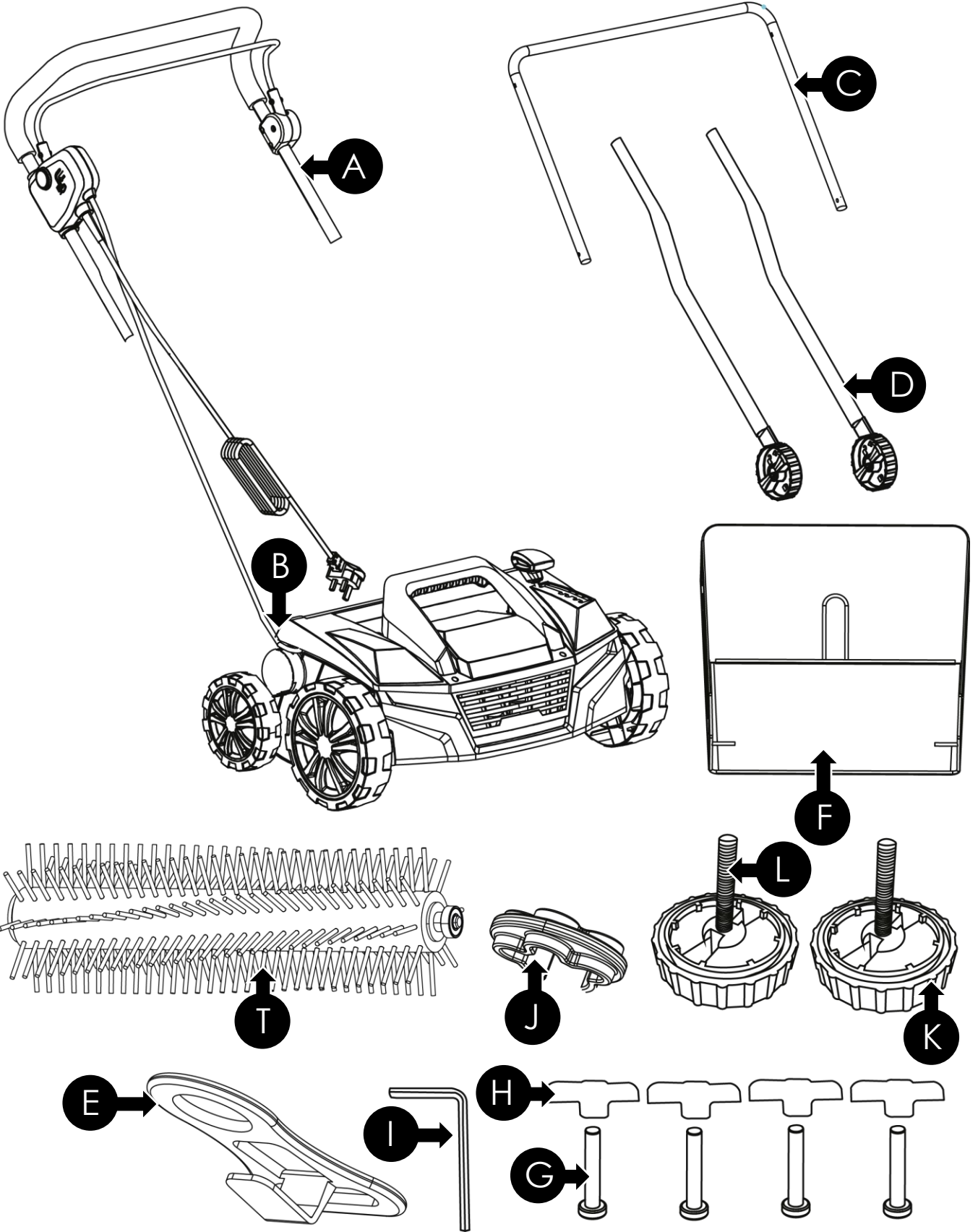

Descriptions on next page 

Features

- A Upper Handle**
You must hold the handlebar with both hands when in use.
- B Main Unit**
- C Middle Bar**
The middle bar connects to the lowers bars.
- D Lower Bars**
The lowers bars connect to the main unit.
- E Power Cable Relief Hook**
This holds the cable in place while in use and prevents strain on the cable.
- F Collection Basket**
- G 4 x Bolts**
These secure the bars together.
- H 4 x Wing Nuts**
These secure the bars together. You can loosen them to fold the handlebar down for storage.
- I Hex Key**
- J Cable Clip**
This keeps the cable secure and tight to the machine.
- K Lower Bar Lock**
This locks the lower bar into place.
- L Lower Bar Lock Bolt**
- T Sweeper/Brush Cartridge (attached to machine)**

Features

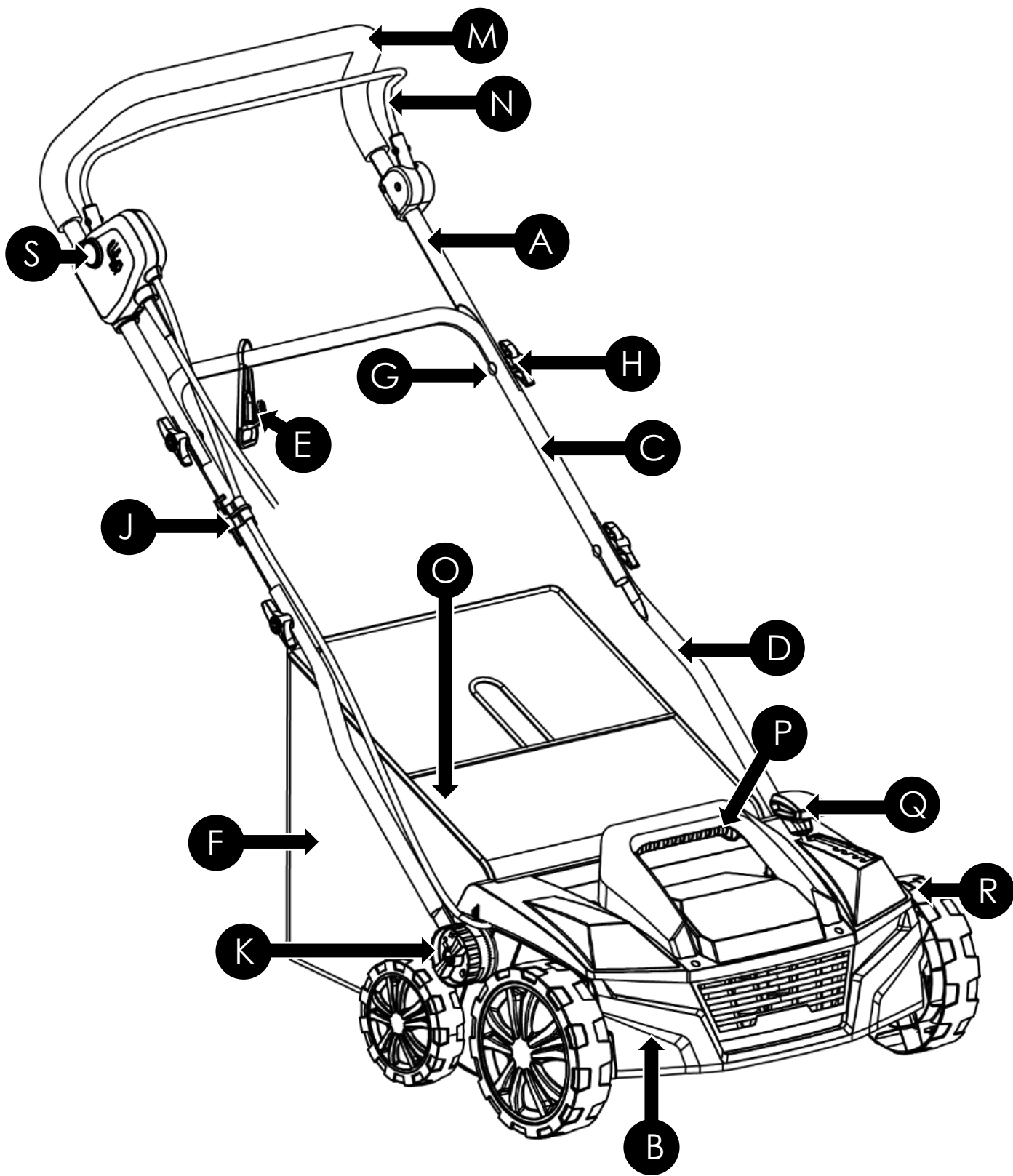

Descriptions on next page 

Features

- A Upper Handle**
This connects to the middle bar.
- B Main Unit**
- C Middle Bar**
The middle bar connects to the lowers bars.
- D Lower Bars**
The lowers bars connect to the main unit.
- E Power Cable Relief Hook**
This holds the cable in place while in use and prevents strain on the cable.
- F Collection Basket**
- G 4 x Bolts**
These secure the bars together.
- H 4 x Wing Nuts**
These secure the bars together. You can loosen them to fold the handlebar down for storage.
- J Cable Clip**
This keeps the cable secure and tight to the machine.
- K Lower Bar Lock**
This locks the lower bar into place.
- M Main Handlebar**
You must hold the handlebar with both hands when in use.
- N Operator Presence Control (OPC) Handle**
This is a safety feature. The machine will stop if you let go of this lever.
- O Protective Rear Cover**
- P Front Handle**
- Q Depth Adjustment Handle**
You can use this to adjust the working depth.
- R Wheel**
- S Safety Button**
This helps prevent the machine starting accidentally.

Assembly

Assembly Overview

There are 8 steps to the assembly:

STEP 1. Attach The Lower Handles

STEP 2. Attach The Middle Bar

STEP 3. Attach The Upper Handle

STEP 4. Attach Cable Clip

STEP 5. Assemble The Collection Basket

STEP 6. Attach The Collection Basket

STEP 7. Cable Relief Hook

STEP 8. Working Depth Adjustment

STEP 1 : Attach The Lower Handles

1. Slot the lower bars (**D**) into place on the main unit. You can choose from 3 different handlebar heights. You can choose the height by aligning the arrow with the desired height option.

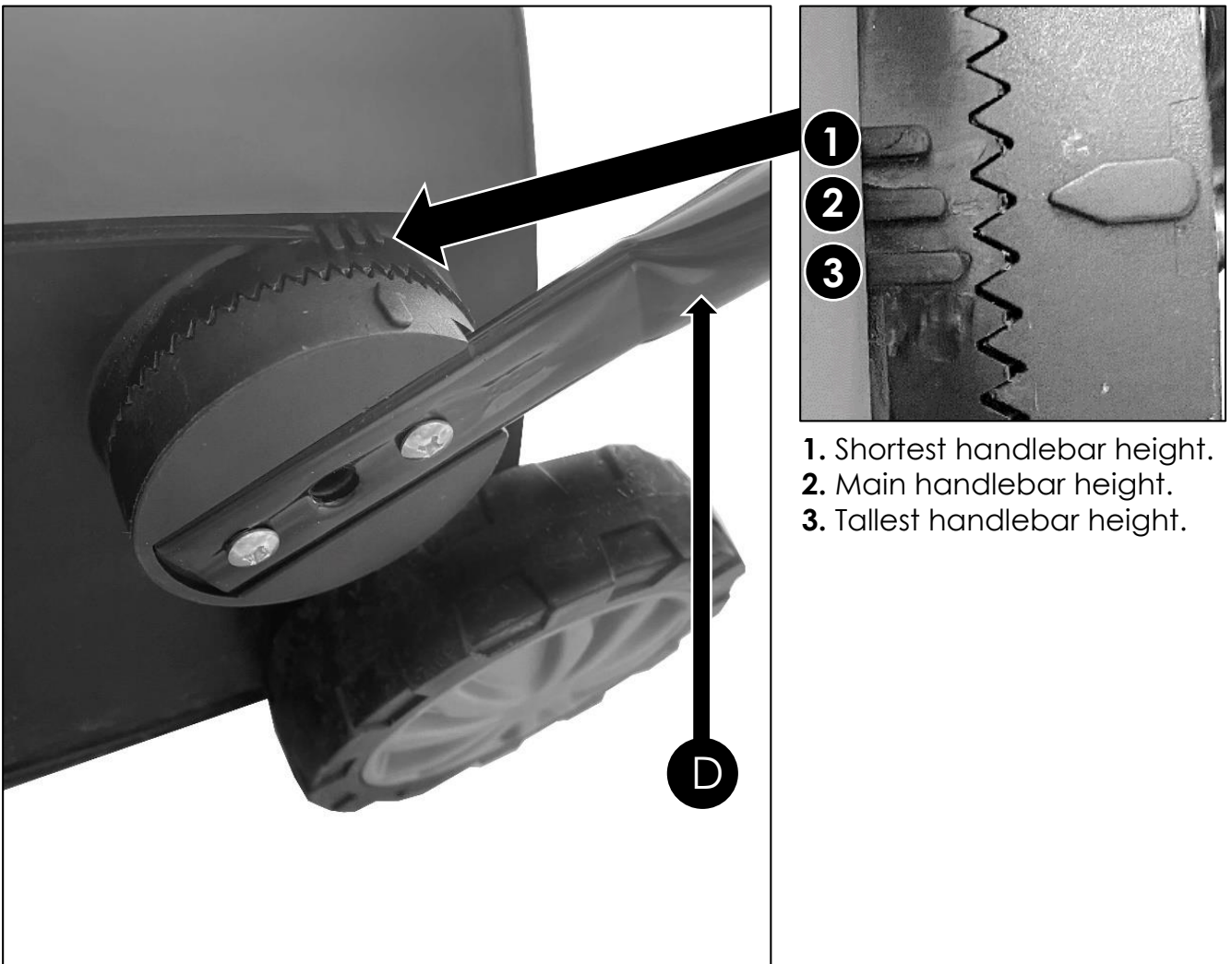

- 1
- 2
- 3

1. Shortest handlebar height.
2. Main handlebar height.
3. Tallest handlebar height.

Assembly

STEP 1 : Attach The Lower Handles (Continued)

2. Screw in the lower bar lock (K) until it is tight and secure. Turn clockwise to lock and anti-clockwise to unlock.



3. The sweeper/brush should now look like the image below.



Assembly

STEP 2 : Attach The Middle Bar

1. Slide the cable relief hook (E) onto the middle bar (C).

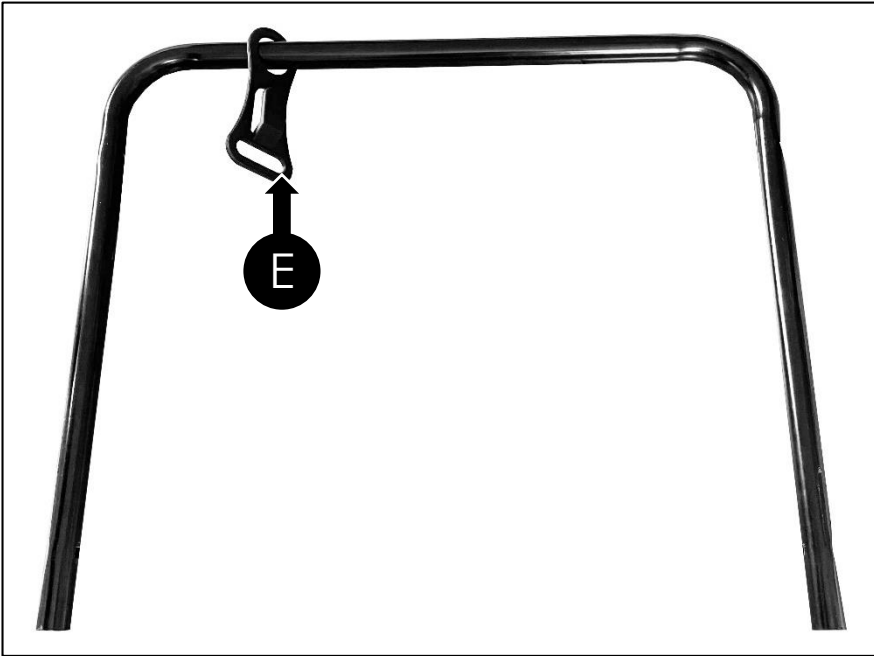

2. Connect the middle bar (C) to the lower bars (D) using the wing nut (H) and bolt (G).

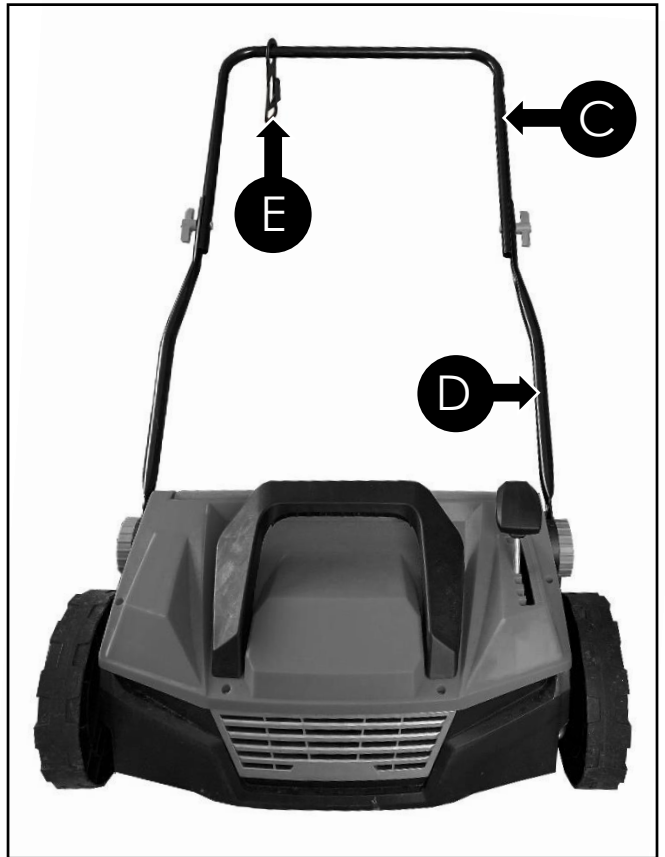
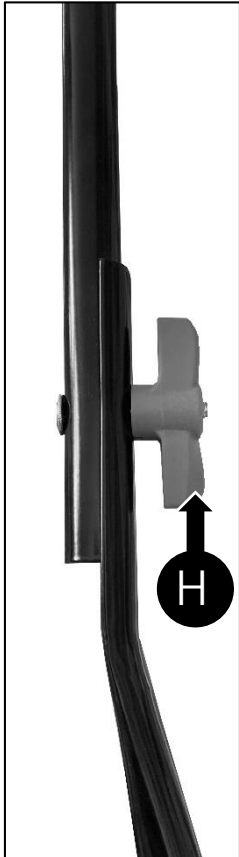
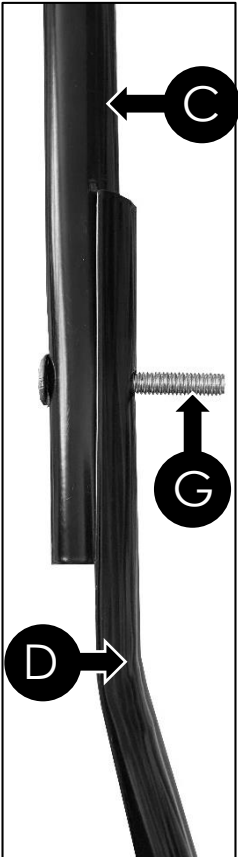

Assembly

STEP 3 : Attach The Upper Handle

1. Connect the upper bar (A) to the middle bar (C) using the wing nut (H) and bolt (G). Make sure the upper bar is attached the correct way as shown in the image.
2. Make sure that the cable relief hook (E) is on the middle bar (C).

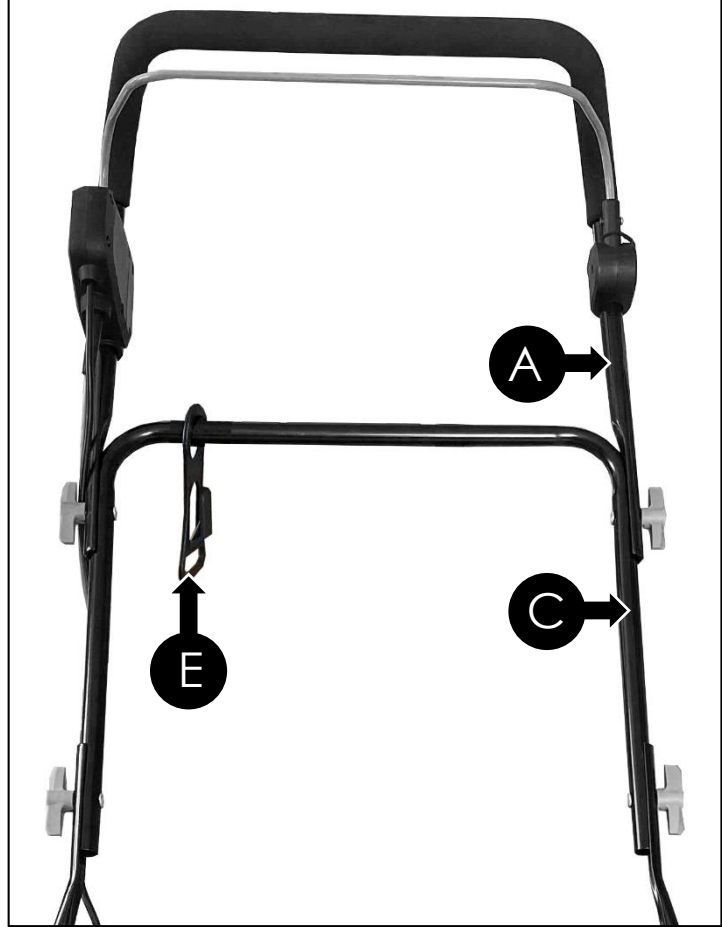
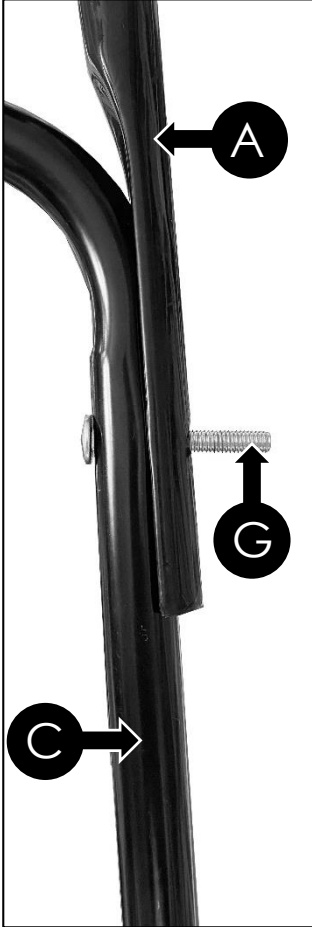

Assembly

STEP 4 : Attach Cable Clip

1. Clip the power cord (**X**) onto the middle bar (**C**) using the cable clip (**J**). This will keep the cable secure and tight to the machine.
2. You can also store the hex key (**I**) in the cable clip (**J**) as shown in the image.

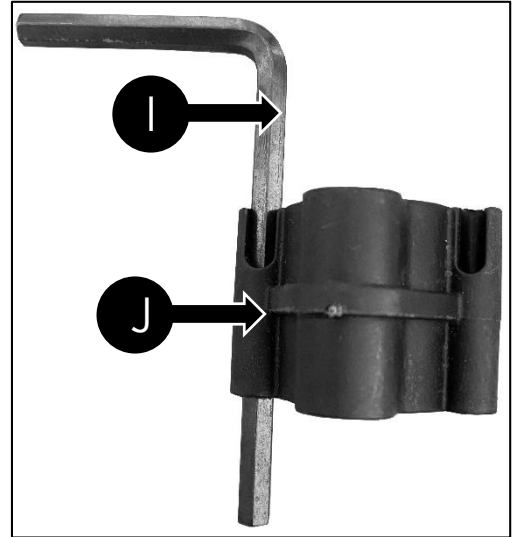
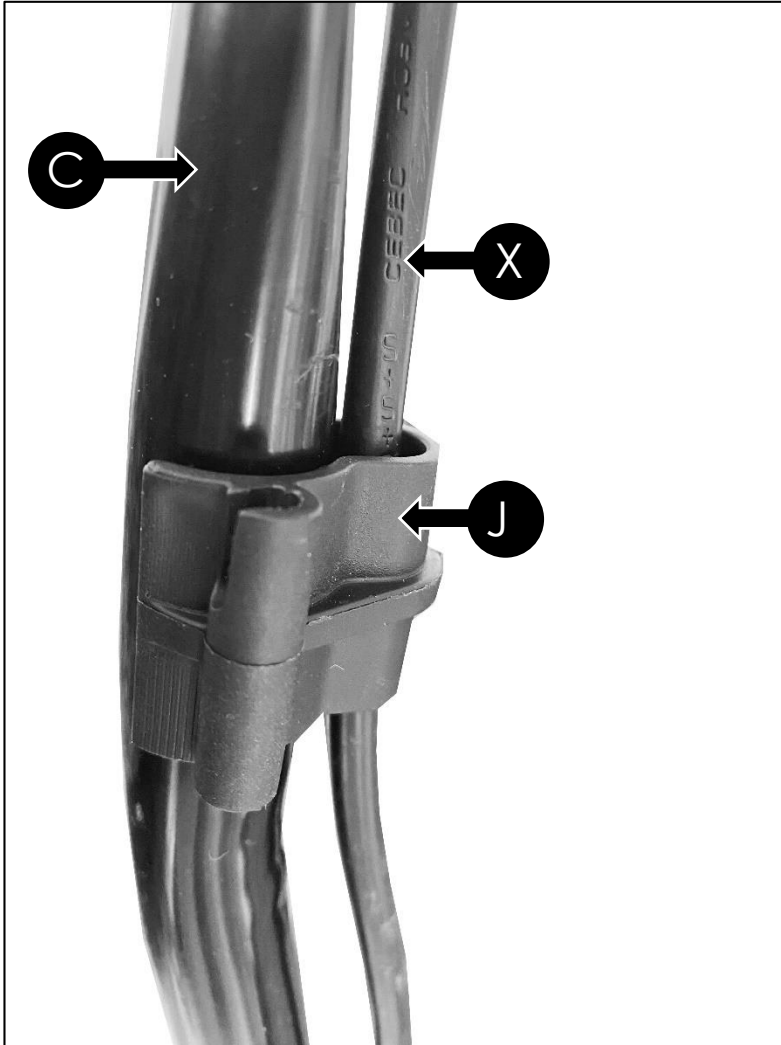

Assembly

STEP 5 : Assemble The Collection Basket

1. Place the metal frame (F1) into the collection bag (F). Attach all fasteners (F2) and make sure they are secure.

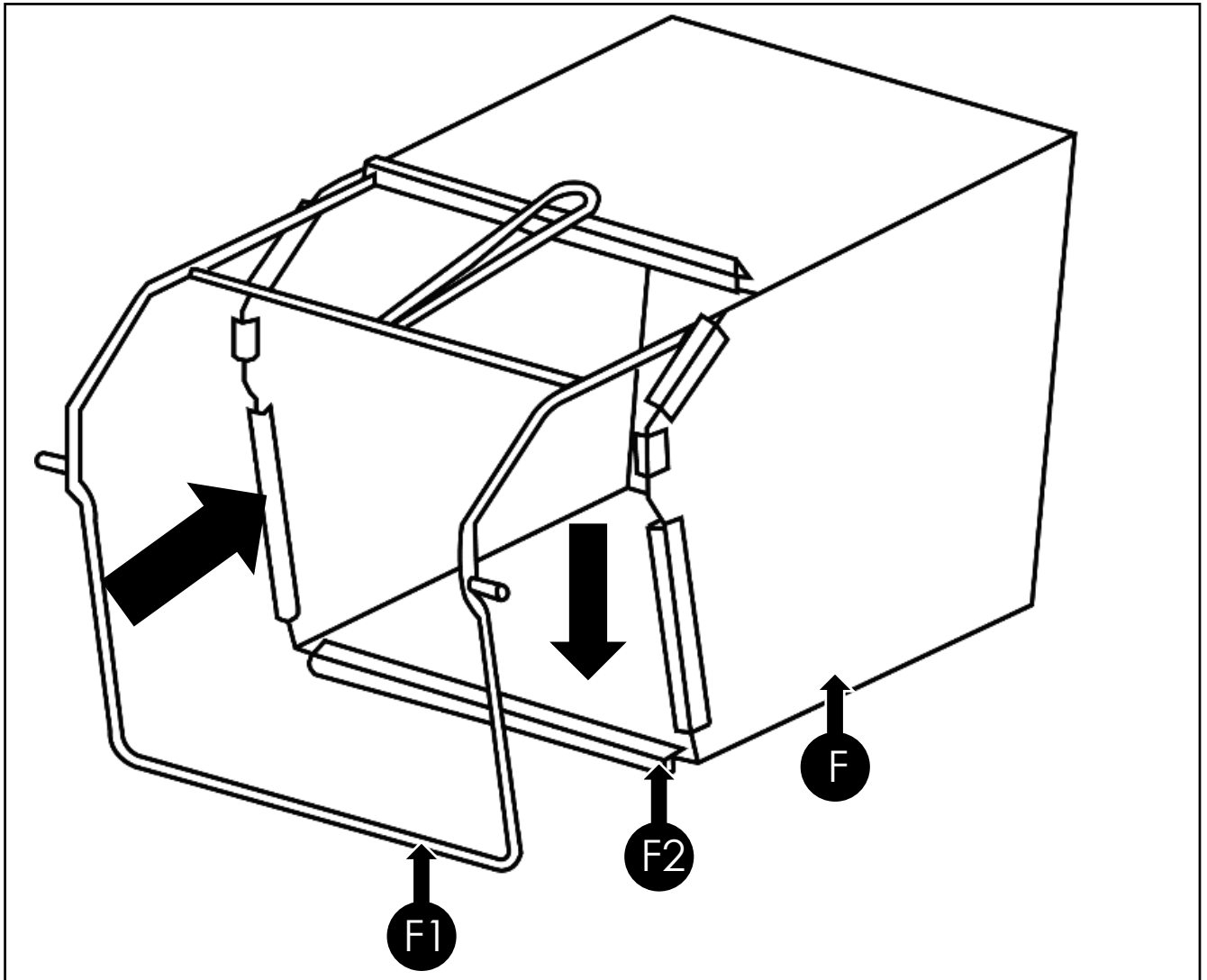

⚠ WARNING!

Ensure the floor of the collection basket is fully extended downward. This is key for the machine to affectively collect debris on your artificial lawn.

Assembly

STEP 6 : Attach The Collection Basket

⚠ You must attach the collection basket before use.

1. Make sure the collection basket is correctly assembled.
2. Lift up the protective rear cover **(O)**.
3. Make sure that the rear chute is clear and free of debris.
4. Clip the collection basket onto the hooks **(Y)**.
5. Place the protective rear cover **(O)** on top of the collection basket **(F)** and check that the collection basket is fitted correctly.

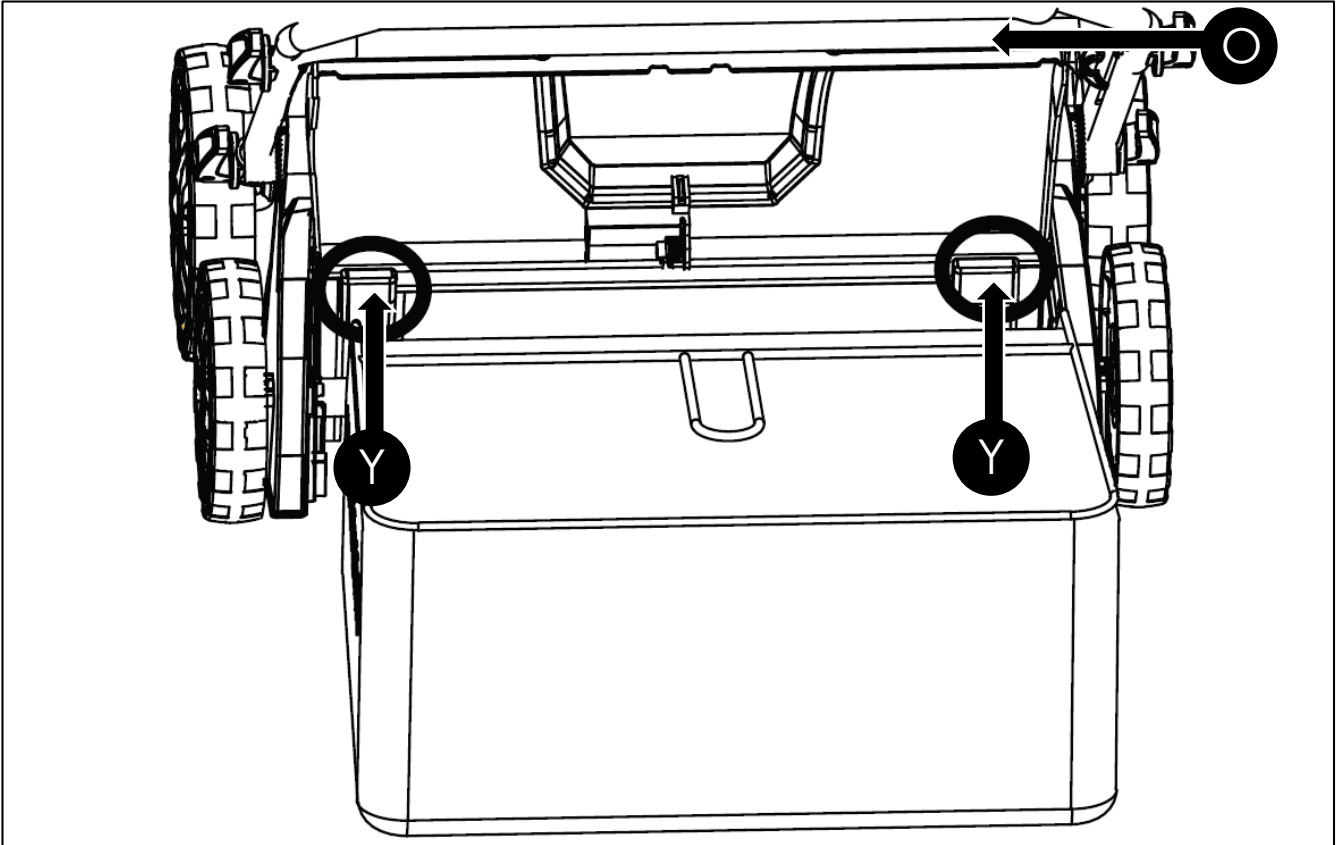

To Remove

1. Lift up the protective rear cover **(O)**.
2. Lift the collection basket off the hooks **(Y)**.
3. Empty the contents of the collection basket and replace before resuming work.

Assembly

STEP 7 : Cable Relief Hook

⚠ Make sure the machine is disconnected from power before you do this

This holds the cable in place while in use and prevents strain on the cable.

1. Make a small loop in the power cable **(X)**.
2. Put the loop through the hole in the cable relief hook **(E)**.
3. Slowly pull the loop to remove slack.

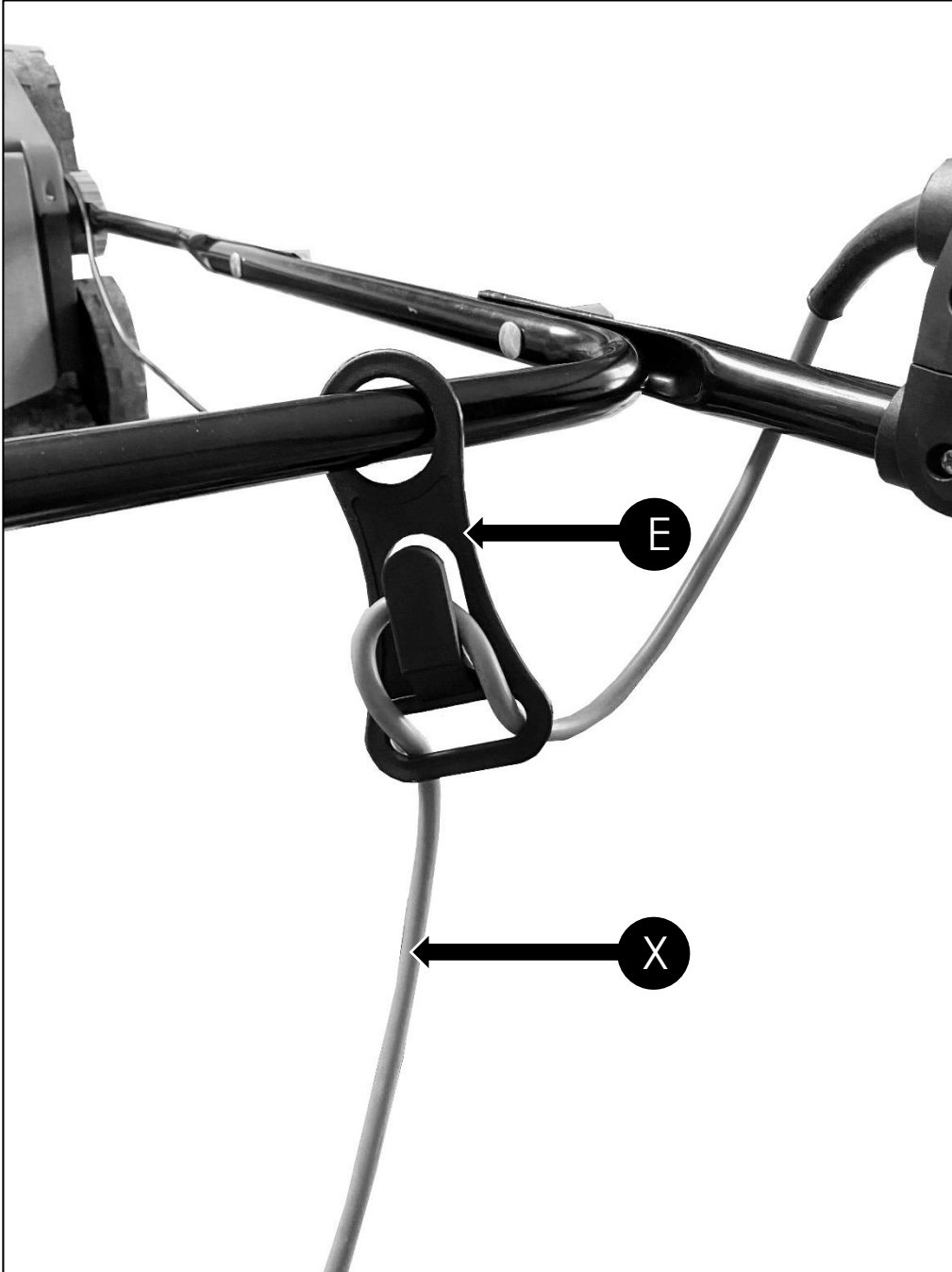

Assembly

STEP 8 : Working Depth Adjustment

The working depth is adjustable to 5 heights (-12mm, -9mm, -6mm, -3mm and +6mm).

1. Push the depth adjustment handle **(Q)** forwards or backwards to adjust the height.

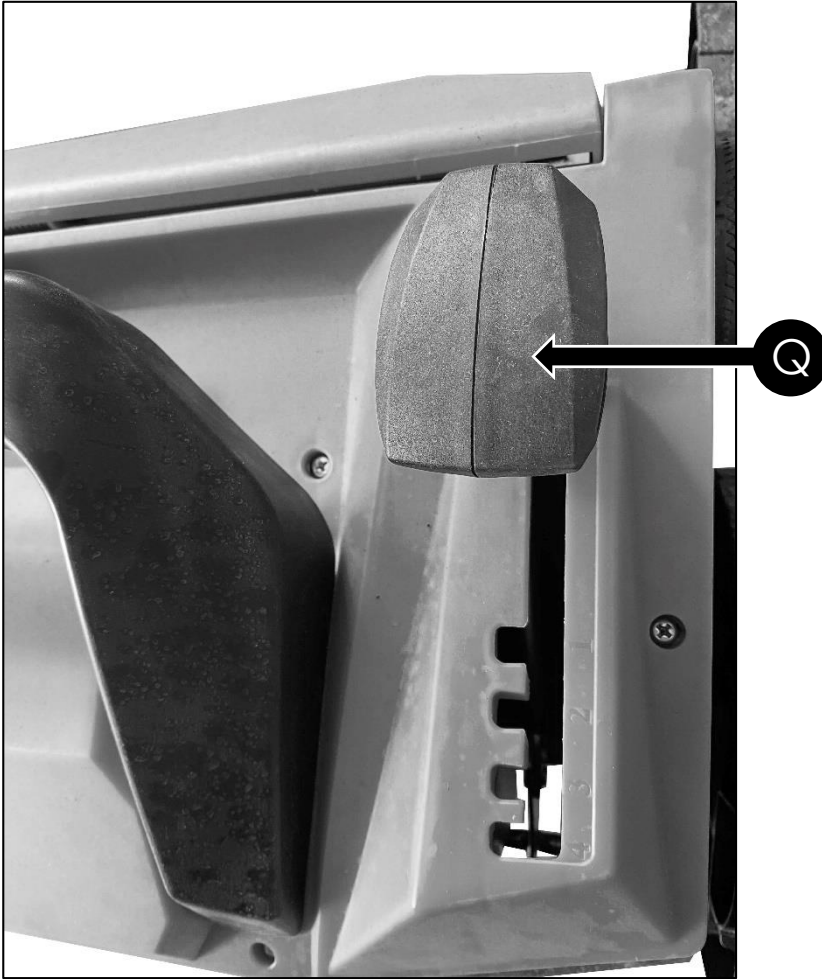

Operation

Preparing Your Artificial Lawn for Sweeping/Brushing

The HYSW1600E is intended to brush artificial grass and sweep small garden debris. If the HYSW1600E is used on excessively dirty artificial grass, dust and small particles of dirt can be thrown into the air. Dust and dirt can build up between the grass fibres, the HYSW1600E brushes these fibres clean, allowing a deep rejuvenation of the artificial grass.

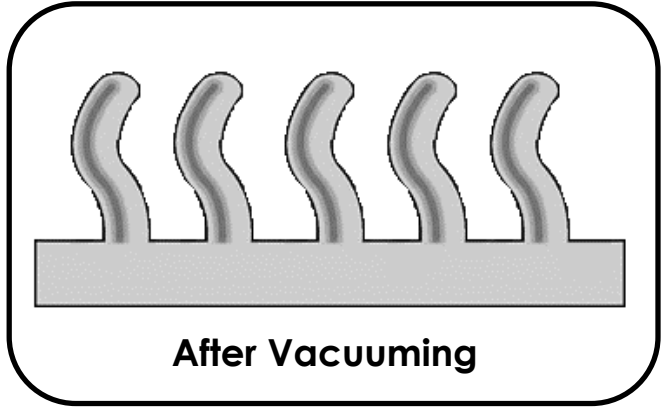
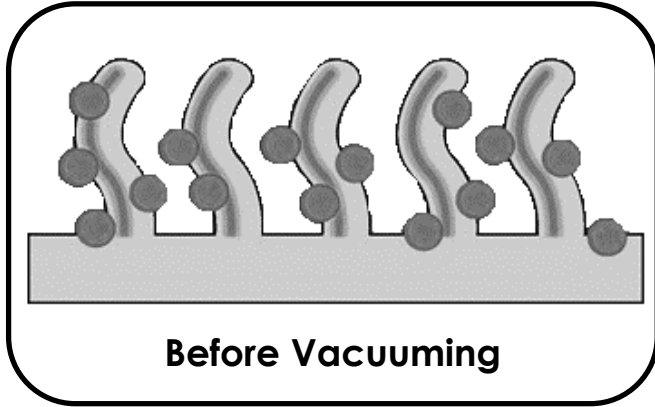

Vacuuming the artificial grass with a suitable wet/dry vacuum before brushing can prevent this, or decrease the amount of dust that is within the fibres of the artificial grass.

 Always ensure the lawn is always dry, and avoid using the HYSW1600E in wet conditions.

Operation

Working Direction

We recommend to use your machine as outlined below to achieve optimum results and to reduce the risk of cutting the mains cable.

⚠ WARNING! DO NOT WORK TOWARDS THE CABLE.

1. Place the bulk of the mains cable close to the starting point.
2. Move from position 1 to position 2.
3. Turn right and proceed towards position 3.
4. Turn left and move towards position 4.
5. Repeat the above steps as required.

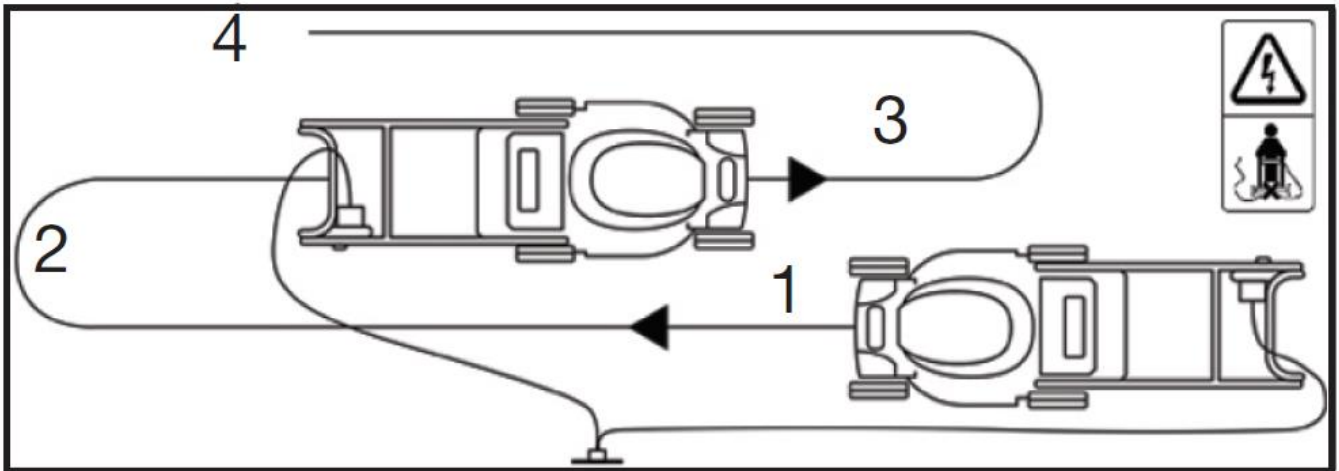

Self Propulsion

The HYSW1600E has an element of self-propelled motion. As the bristles rotate, they will pull the machine along. The lower the setting on the machine, the more intense the self-propulsion will be. We recommend to start off the machine always on the highest setting to familiarise the user with the operations of the machine.

Sweeping Near Walls or Raised Borders

The HYSW1600E, will leave a 10cm gap to walls. If turfed area is surround by walls or raised borders, there will be a 10cm border. It is recommended to use a Strong Bristle Garden brush to aerate the turf in areas the sweeper can't reach.

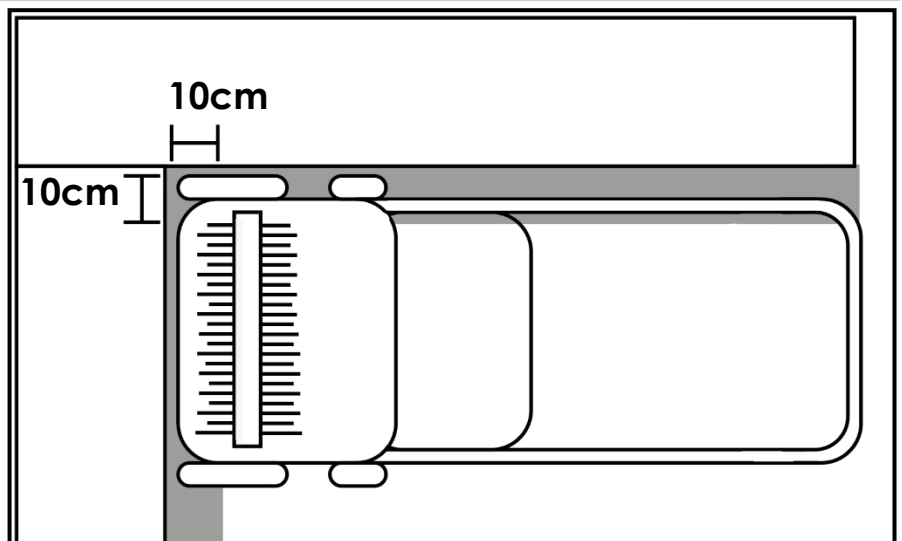

Operation

Tips and Tricks for Brushing/Sweeping

When first installing artificial grass, you'll find the grass blades matted and flat; Using the HYSW1600E will refresh the appearance of the grass, making the blades stand upright and aerated. First you neutralize the grain. You must brush a path in both directions in order to prepare the lawn for usage and striping.

Neutralizing the Grain

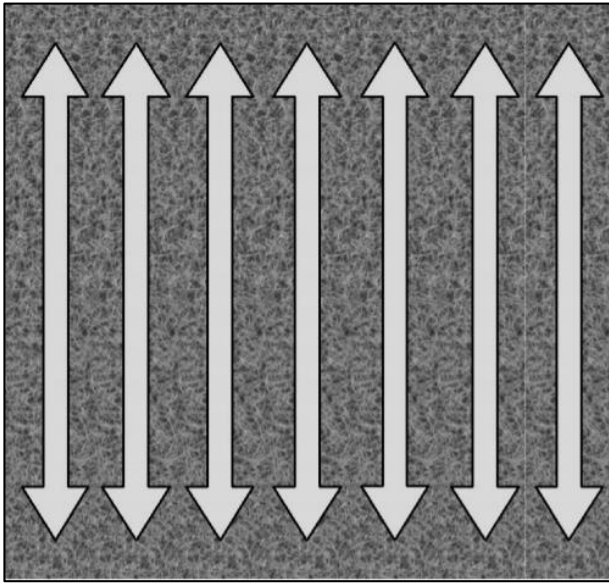

Before Brushing



After Brushing

Lawn Striping

It is possible to add lines to artificial grass as with conventional lawns. When sweeping/ brushing your artificial grass, alternate the direction of the machines path to create lawn stripes.

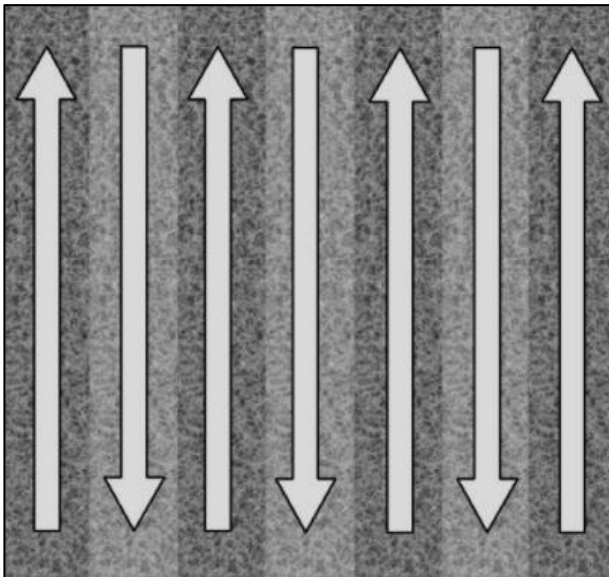

Operation

Before Starting Work

1. Check the condition of the cable, if damaged do not use.
2. Ensure that no objects or branches are trapped into the machine.
3. Ensure the work area is tidy and free of any obstacles.
4. Never operate the machine if it is damaged in any way.

Starting

⚠ YOU MUST read and understand the full safety instruction manual before starting the machine.

1. Before starting the motor, make sure the cable is well away from the moving parts.
2. Connect to the mains power supply.
3. Press and hold the safety button **(S)**.
4. Pull the OPC lever **(N)** to the handle.
5. Release the safety button **(S)**.

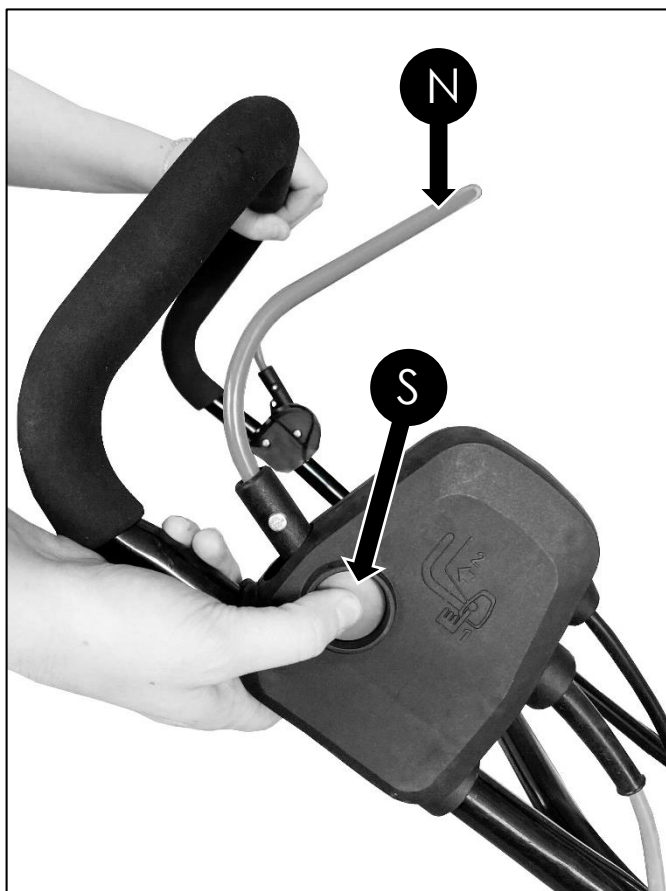

Operation

Stopping

⚠ WARNING : Sweeping/brushing elements continue to rotate for a moment after the motor is switched off. Do not touch the underside of the machine until the sweeper/brush has come to a standstill.

⚠ WARNING : Always switch off machine before placing it down.

1. Release the OPC lever (**N**).
2. Unplug from the mains supply.



Maintenance & Care

General Maintenance

⚠ WARNING : Turn OFF the machine, allow all moving parts to come to a complete stop, and disconnect the power cord before maintaining the machine. You need to wear proper clothing and protective gloves whenever your hands are at risk.

- Keep all nuts, bolts and screws tight to be sure the machine is in a safe working condition.
- Replace worn or damaged parts for safety. Only use manufacturer-recommended parts and accessories.

Storage

⚠ Keep the machine stored in a dry, level area away from damp, moisture and rain fall. Allow the machine to cool down before storing.

- Make sure the machine is clean and dry before storing.
- Make sure the machine is stored away from direct sunlight. Store indoors or in a safe, locked protected area during severe weather and winter months.
- Ensure the machine is stored in a position, where any persons cannot step on to attempt to reach items up high, due to risk of movement.
- DO NOT store the machine near an ignition source, such as a wood stove, gas or electric heater, or an appliance or heater with a pilot light.
- Store the machine out of reach of children or anyone who is not familiar with operation.
- DO NOT stack other items on top of the machine when in storage.

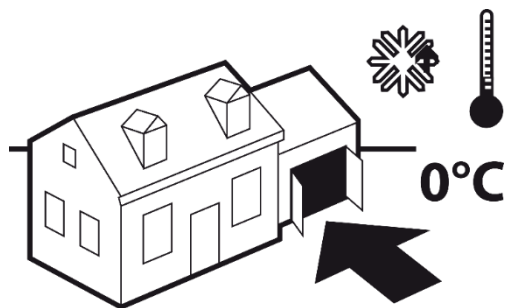

Cleaning

⚠ Always remove the electric plug from the mains supply before any cleaning is undertaken.

- Remove any grass and mud after each use to prevent it from drying. Use a clean cloth to remove dirt, grease, etc.
- DO NOT use any water on any part of the main machine.
- Avoid using solvents when cleaning plastic parts. Most plastics are susceptible to damage from various types of commercial solvents and may be damaged by their use.
- Always ensure that ventilation openings are kept clear of debris.

Maintenance & Care

Cleaning / Replacing The Brush Cartridge

⚠ WARNING! When carrying out maintenance on the Brush Cartridge. Ensure the machine is **UNPLUGGED** from the power source. Ensure you allow the machine to stop completely before carrying out any maintenance.

! Taking the Brush Cartridge out will make it easier to clean. Strands of material can become tangled on the cylinder.

1. Unscrew the bolt on the underside of the machine, using the hex key provided.



Maintenance & Care

Cleaning / Replacing The Brush Cartridge (Continued)

2. Lift the Brush Cartridge at an angle and pull it out.

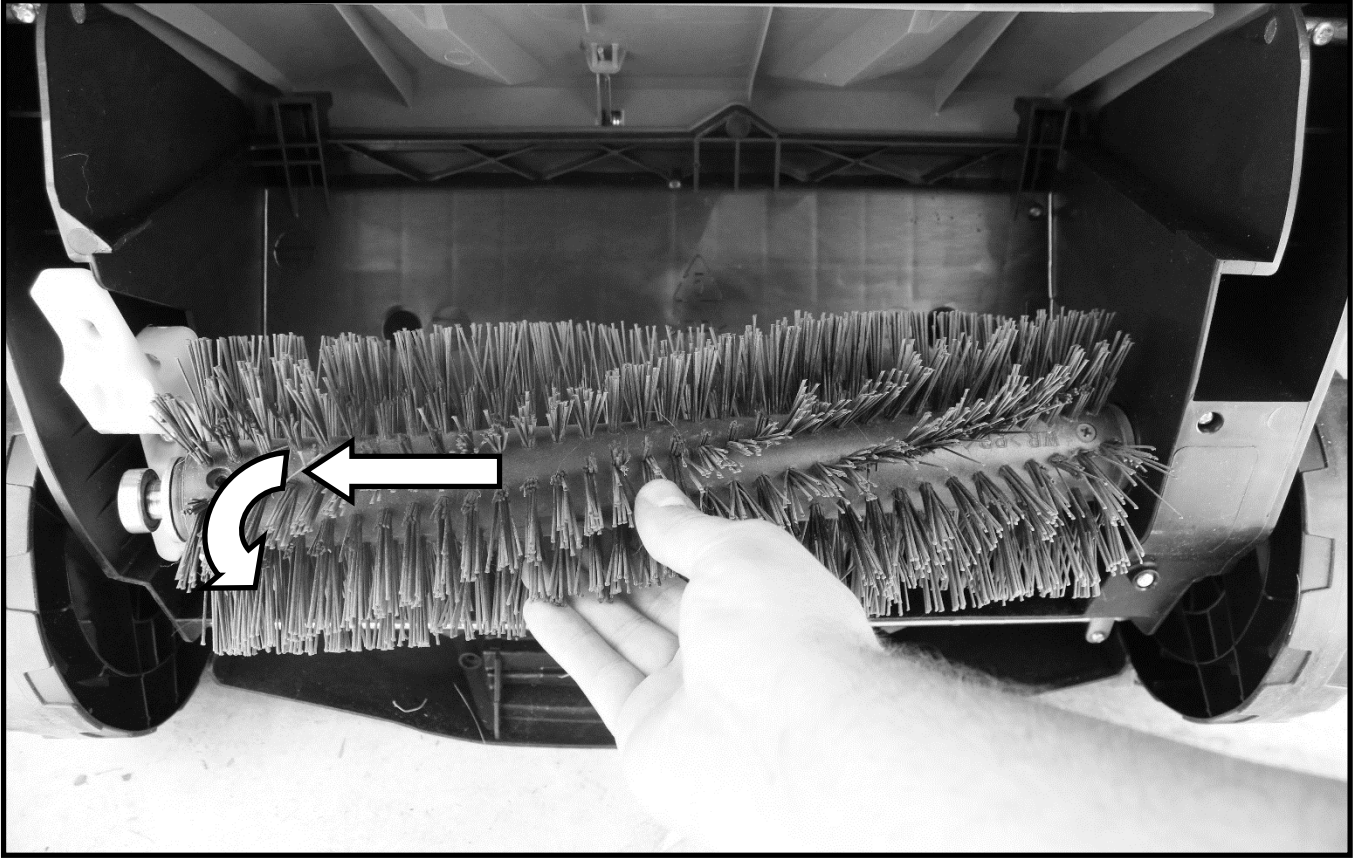

3. Repeat the steps backwards to re-install the brush cartridge.

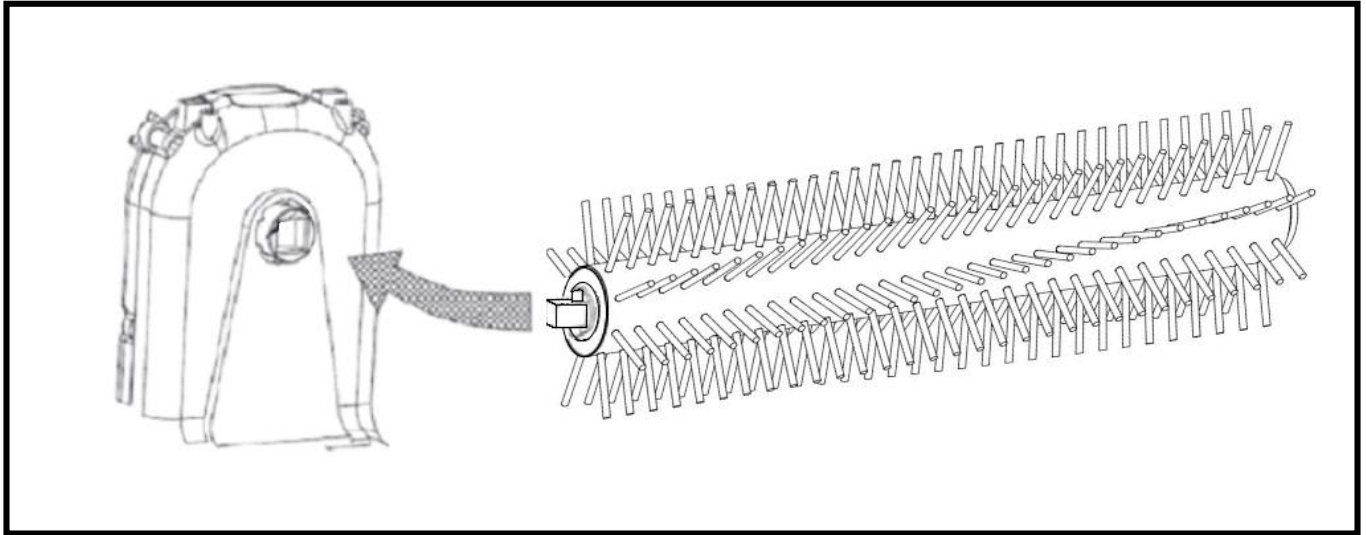

Replacement brushes available at: www.hyundaipowerproducts.co.uk

Maintenance & Care

Troubleshooting

⚠ NOTE : All corrective actions should be carried out by suitably qualified person/s.

Problem	Possible Cause	Possible Solution
Machine will not start.	Fuse in mains plug blown / faulty	Check fuse in mains plug and replace if necessary.
	Internal wiring fault.	Contact your service dealer.
Machine functions intermittently.	Internal wiring fault.	Contact your service dealer.

Maintenance & Care

Spare Parts

⚠ Only use original spare parts: The use of non-original and/or incorrectly fitted parts will jeopardise the safety of the machine, may cause accidents or injuries for which the manufacturer is under no circumstance liable or responsible.

- 1 Find the part you are looking for in the drawings.
- 2 Information about the parts can be found in the tables below or visit power-spare.co.uk
- 3 Use this information to order the part.
- 4 Contact us if you need help finding the correct part.

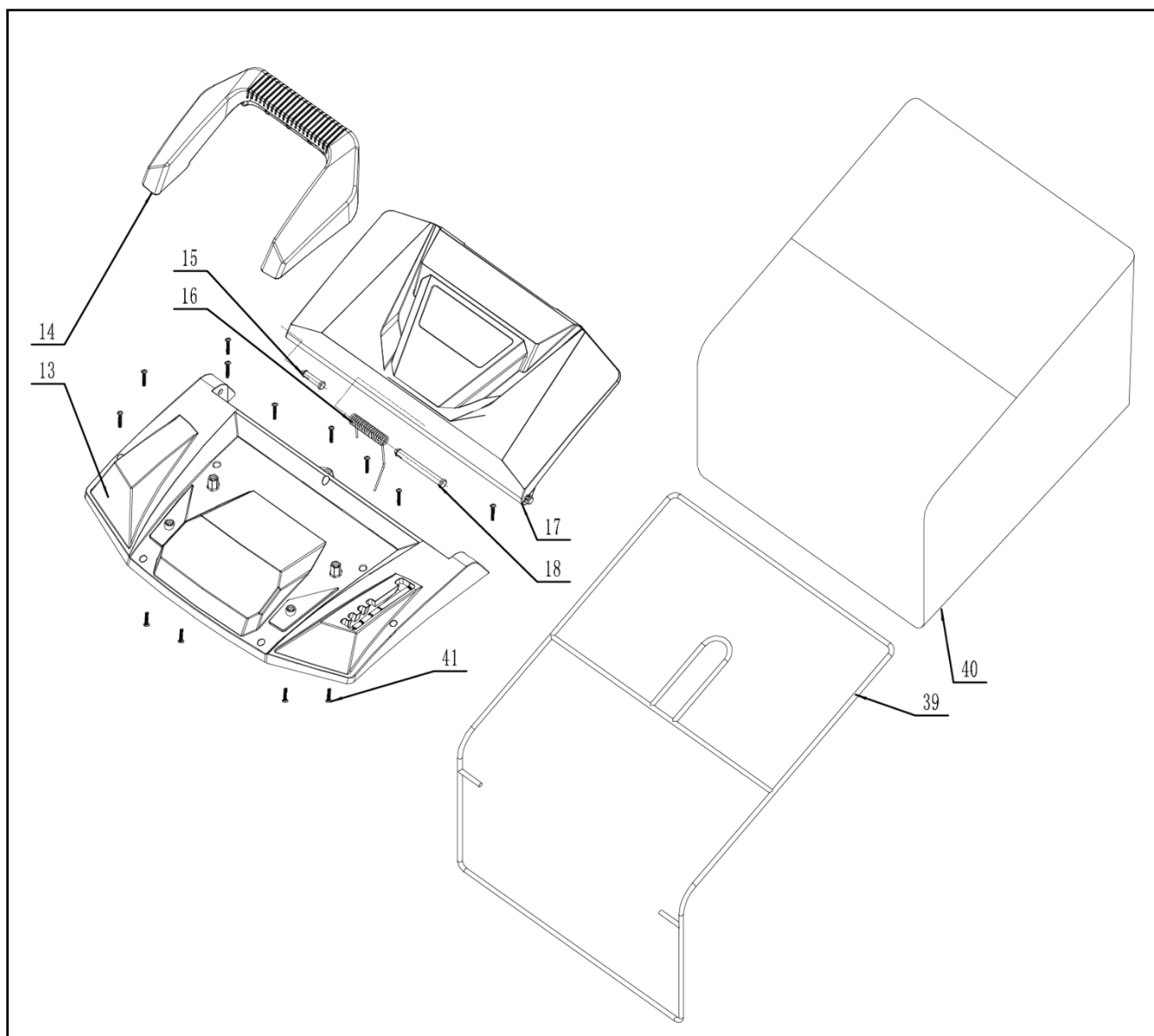

Maintenance & Care

Spare Parts

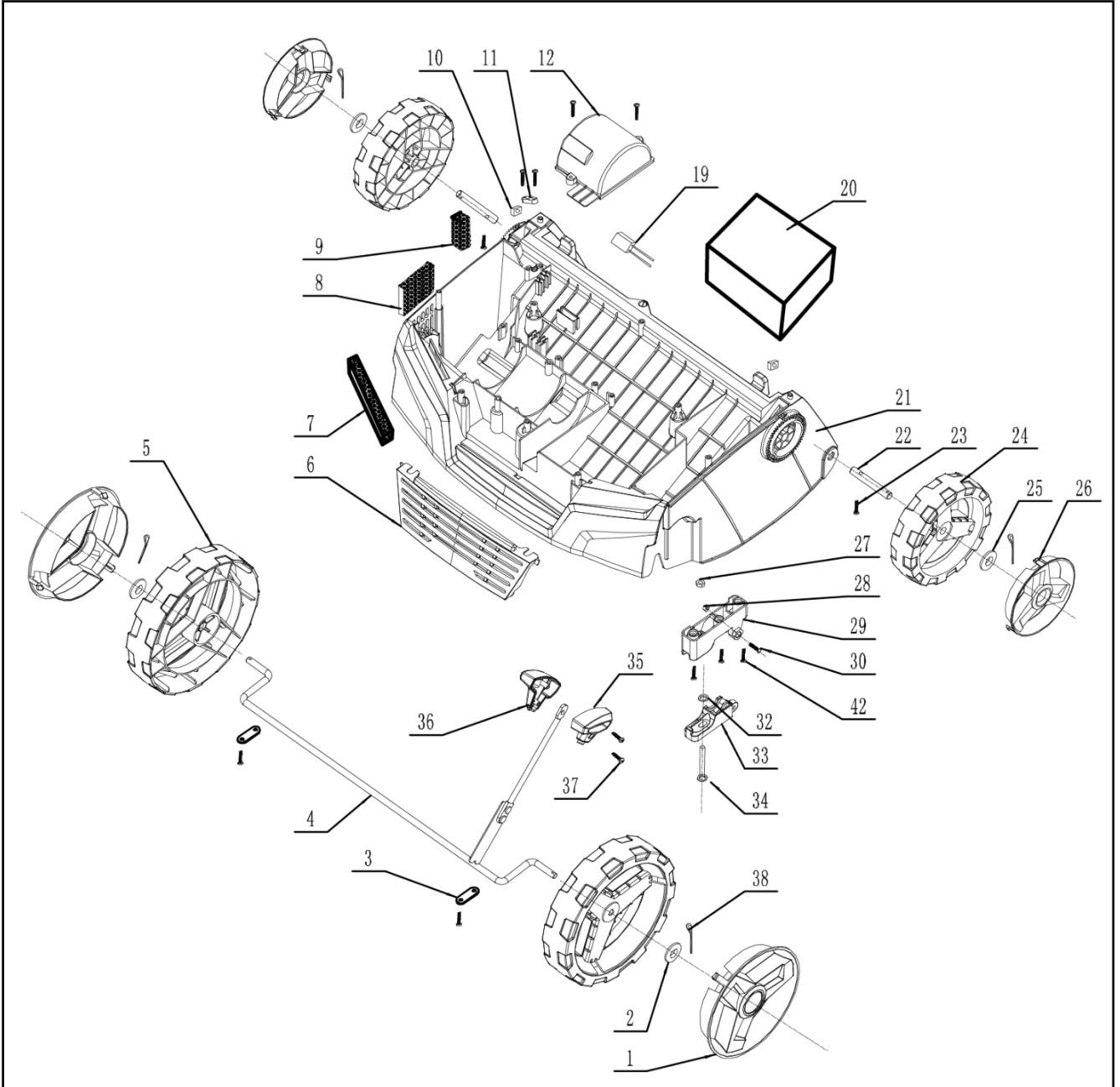

Maintenance & Care

Spare Parts

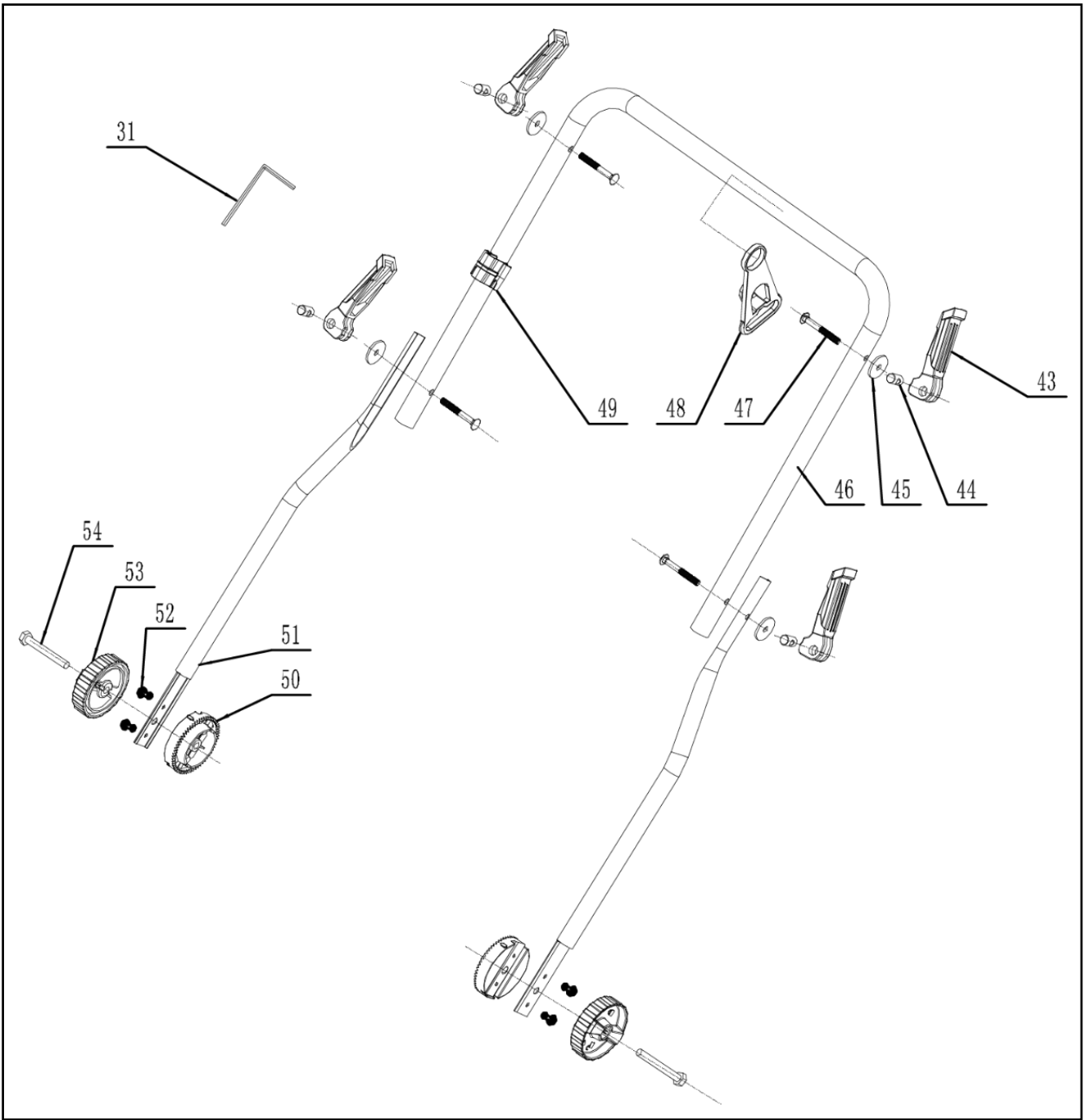

Maintenance & Care

Spare Parts

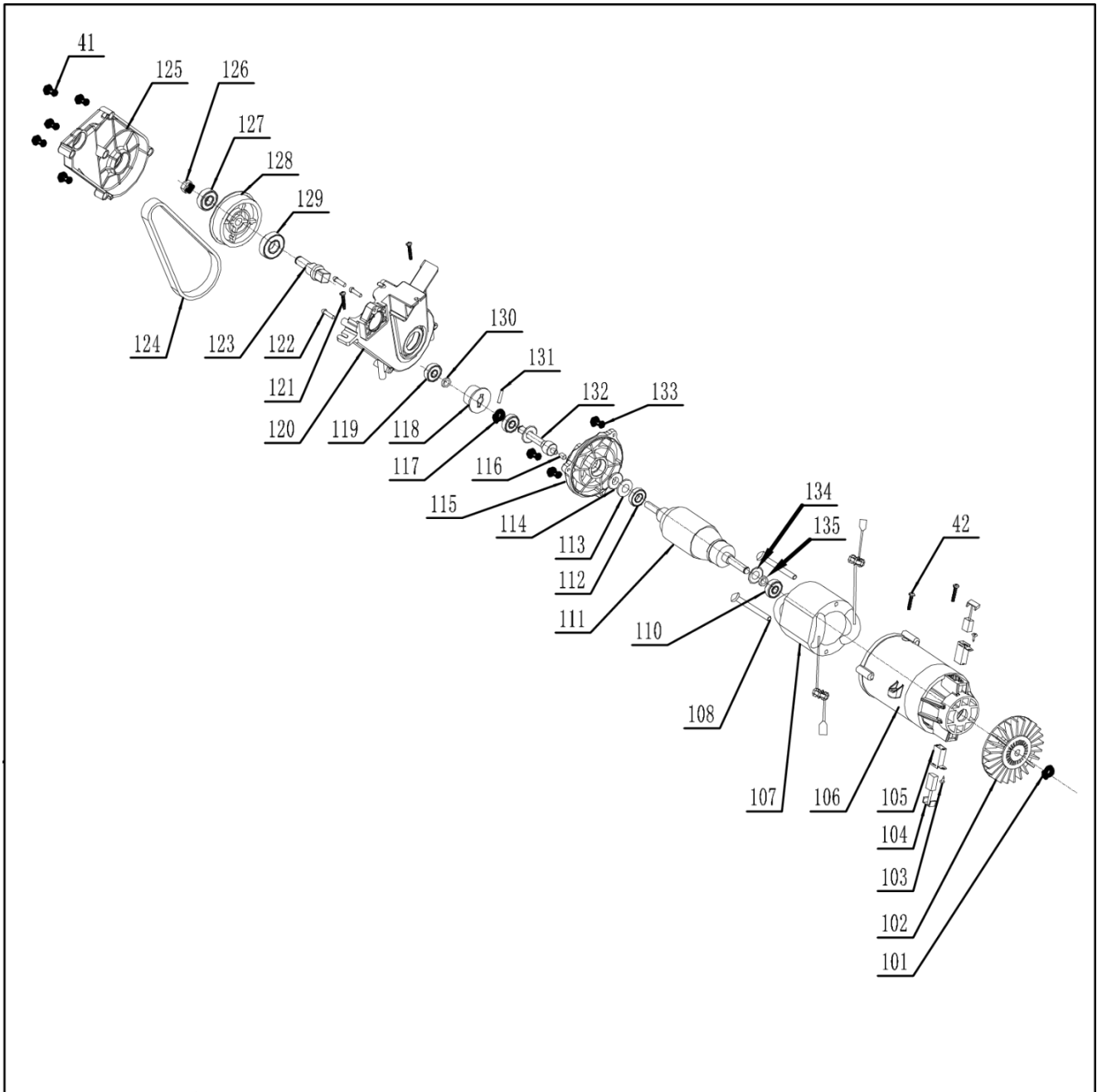

100

Maintenance & Care

Spare Parts

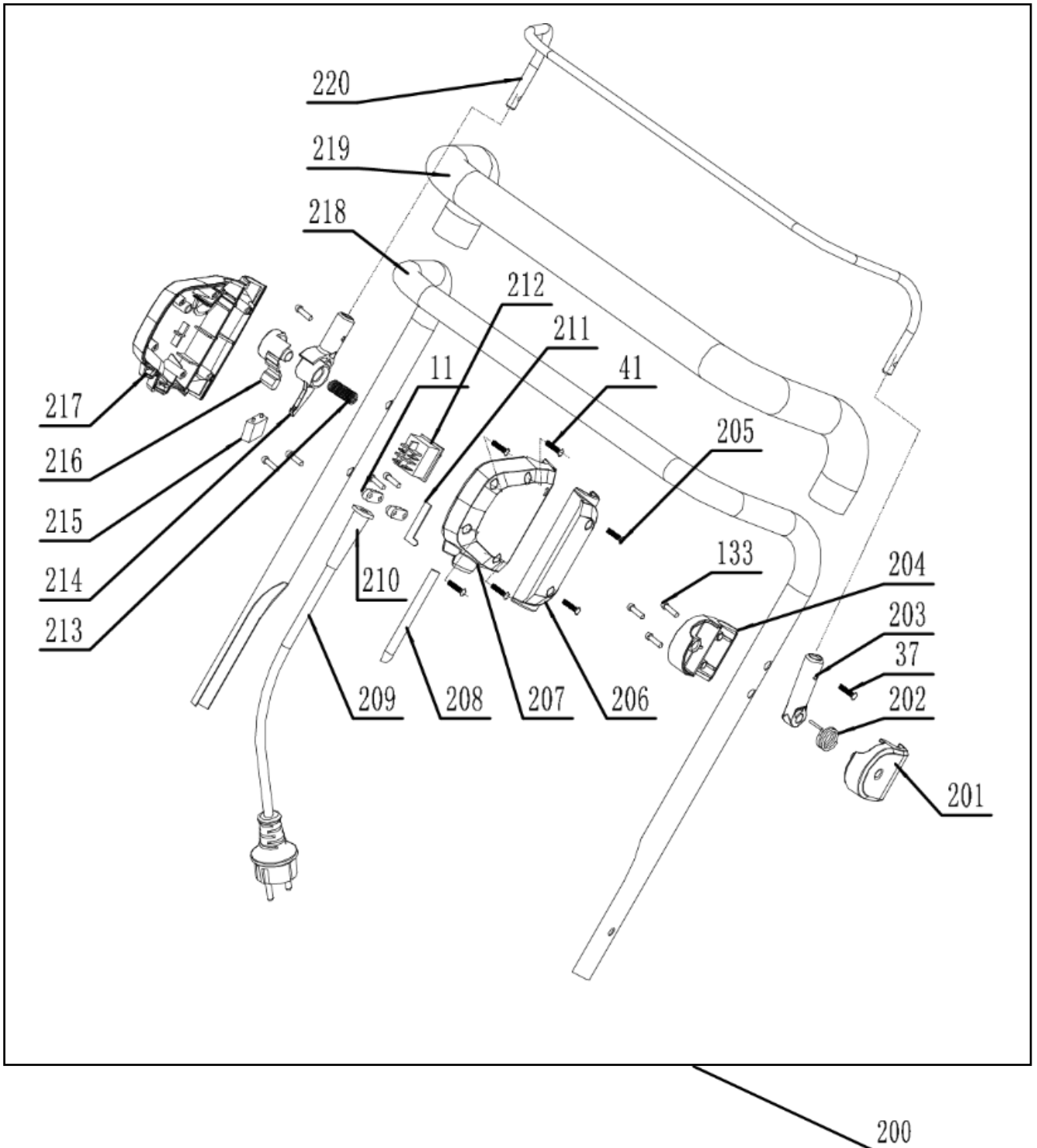

Maintenance & Care

Spare Parts

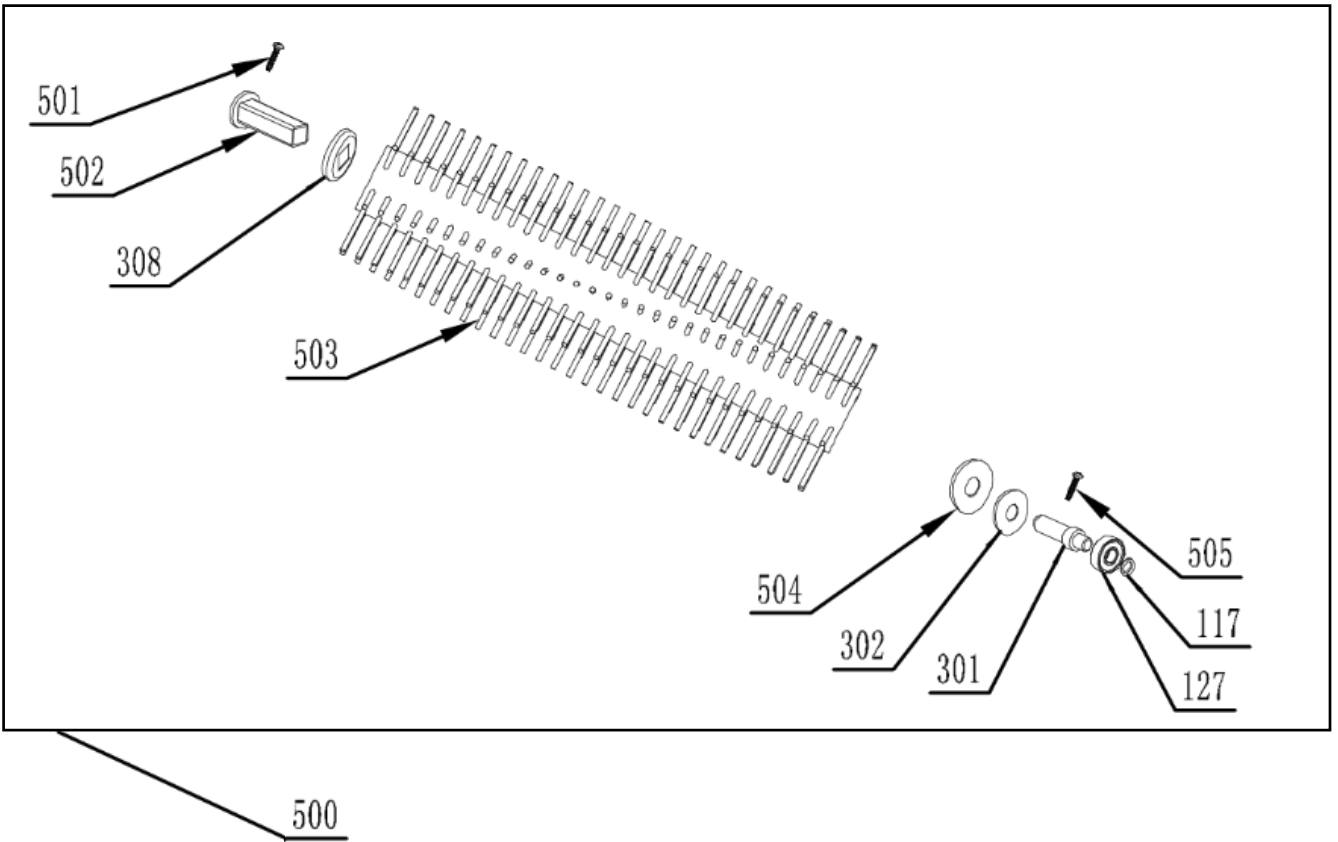

Maintenance & Care

Spare Parts

Drawing Number	Spare Part Name	Part Number
1	Wheel Cover	1355001
2	Φ8*Φ16*1.5 Gasket	1355002
3	Pressplate	1355003
4	Front Wheel Spindle Assembly	1355004
4-1	Gear Adjust Lever	1355005
4-2	6006 Front Wheel Shaft	1355006
4-3	Gear Adjusting Wrench Assembly	1355007
4-4	Gear Adjusting Shrapnel	1355008
5	200 Wheel	1355009
6	Front Decorative Panel	1355010
7	Filter Sponge NO.2	1355011
8	Filter Sponge NO.1	1355012
9	Filter sponge NO.3	1355013
10	NUT 12*12*6 M8	1355014
11	Pressplate	1355015
12	Breakwind	1355016
13	Housing Cover	1355017
14	Housing Handle	1355018
15	Grass Bag Fixing Pin	1355019
16	Spring	1355020
17	Grass Bag Cover	1355021
18	Torsion Spring Fixing Pin	1355022
19	Protector 17AMG/95G+PTC	1355023
20	Sandbag	1355024
20-1	PE Bag	1355025
20-2	Sand Bag	1355026
21	Base	1355027

Maintenance & Care

Spare Parts

Drawing Number	Spare Part Name	Part Number
22	Back Wheel Spindle	1355028
23	Screw ST5*25	1355029
24	150 Wheel	1355030
25	Φ10*Φ20*1.5 Gasket	1355031
26	Wheel Cover	1355032
27	NUT M6*5	1355033
28	NUT M5	1355034
29	Bearing Block	1355035
30	NUT M5*25	1355036
31	Wrench	1355037
32	Φ6*Φ12*1 Gasket	1355038
33	Press Plate	1355039
34	Nut M6*30	1355040
35	Depth Adjust Handle (right)	1355041
36	Depth Adjust Handle (left)	1355042
37	Screw ST4*16	1355043
38	R PinΦ2*20mm	1355044
39	Grass Collect Frame	1355045
40	Grass Collect Bag	1355046
41	Screw ST4*18	1355047
42	Screw ST5*25	1355048
43	Knob	1355049
44	Nut Φ10*19---M6*0.75	1355050
45	Gasket	1355051
46	No.2 Rod	1355052
47	Screw M6*52	1355053
48	Cable Strain Relief	1355054
49	Cable Clamp	1355055

Maintenance & Care

Spare Parts

Drawing Number	Spare Part Name	Part Number
50	No.1 Rod Seat	1355056
51	No. 1 Rod	1355057
52	Screw ST4*12	1355058
53	Knob	1355059
54	Screw M8*50	1355060
100	Motor Assembly	1355062
101	Ring Φ 8	1355063
102	Motor Fan	1355064
103	Screw ST3*12	1355065
104	Carbon Brush	1355066
105	Carbon Brush Holder	1355067
106	Housing	1355068
107	Stator Assembly	1355069
107-1	Inductance	1355070
108	Screw ST4*65	1355071
109	Gasket Φ 21* Φ 16.5*2	1355072
110	Bearing 608-2RS	1355073
111	Rotor Assembly	1355074
112	Bearing 6900-2RS	1355075
113	Gasket Φ 10.1*22*0.5	1355076
114	Wool Felt Φ 8* Φ 16*1.5	1355077
115	Gear Box	1355078
116	Bearing HK0608	1355079
117	Ring Φ 10	1355080
118	Wheel	1355081
119	Bering ZZ-608	1355082
120	Centre Frame	1355083
121	Screw ST4*20	1355084

Maintenance & Care

Spare Parts

Drawing Number	Spare Part Name	Part Number
122	Screw M4*20	1355085
123	Output Axis	1355086
124	Belt	1355087
125	Centre Frame Cover	1355088
126	Nut	1355089
127	Bearing6000-2RS	1355090
128	Wheel	1355091
129	Bearing6002-2RS	1355092
130	Gasket	1355093
131	Axis	1355094
132	Axis	1355095
133	Screw ST4*20	1355096
134	Wool Felt	1355097
135	Flat Gasket	1355098
41	Screw ST4*18	1355099
42	Screw ST5*25	1355100
200	Switch Assembly	1355102
201	Trigger Seat Left	1355103
202	Spring	1355104
203	Wire Connected Rod	1355105
204	Trigger Seat Right	1355106
205	Screw ST4*25	1355107
206	Switch Box Pressplate	1355108
207	Switch Box Left	1355109
208	Wire	1355110
209	Pulg	1355111
210	Cable Sleeve	1355112
211	Switch Reset Shrapnel	1355113

Maintenance & Care

Spare Parts

Drawing Number	Spare Part Name	Part Number
212	Rocker Switch	1355114
213	Spring	1355115
214	Trigger	1355116
215	Capacitance	1355117
216	Switch Button	1355118
217	Switch Box	1355119
218	No. 3 Rod	1355120
219	Sponge Tube	1355121
220	Wire Trigger	1355122
133	Screw ST4*20	1355123
11	Cable Pressplate	1355124
37	ScrewST4*16	1355125
41	ScrewST4*18	1355126
500	Brush Roller Assembly	1355128
501	Screw ST5*18	1355129
502	Shaft Sleeve	1355130
503	Brusher Roller	1355131
504	Washer	1355132
505	Screw ST5*25	1355133
117	Shaft Retaining Ring	1355134
127	Bearing 6000-2RS	1355135
301	Connection Shaft Head	1355136
302	Shaft Head Gasket	1355137
308	Dust Cover Plate Left	1355138

Technical Data

Specification

Model	HYSW1600E
Voltage	230-240V
Frequency	50Hz
Rated Power	1600W
Working Width	38cm
Working Depth	+6mm to -12mm
Grass Collector Capacity	45L
Protection Class	IPX4
Cylinder Operating Speed	3500rpm
Sound Pressure Level	L _{pa} = 85.56dB(A) K=3dB(A)
Guaranteed Sound Power Level	L _{wa} = 108dB(A)
Vibrations	5.508m/s ² K= 1.5m/s ²
Net Weight	12.5kg

Recycling & Disposal

Recycling & Disposal

We do not offer a takeback scheme for the recovery of Waste Electrical Electronic Equipment (WEEE) & Batteries. Instead the responsibility to dispose of WEEE and/or Batteries is passed onto you by us.

So when it becomes necessary to dispose of your machine you must take it to your local Civic Amenity Site. For further information please contact your local Authority for disposal advice.

You **MUST** make sure that all unused oil and fuel is disposed of correctly either beforehand or at your local Civic Amenity Site.

- Under NO circumstances must any fuel or oil be put down any drains.
- Certain products contain WEEE waste which should not be disposed of in your domestic waste.
- You **MUST** recycle WEEE in accordance with your local authority or recycling centre.
- Certain products contain batteries which should not be disposed of in your domestic waste.
- You **MUST** recycle batteries in accordance with your local authority or recycling centre.
- Unwanted packaging and materials should be stored and taken to a recycling centre so it can be disposed of in a manner which is compatible with the environment.

We are a Member of the VALPAK National Compliance Scheme and our registration number is RM08660. For further information about disposal please contact your Local Authority.

You can also get more advice and guidance about recycling at the following website <http://www.recycle-more.co.uk>

Should you pass this product on to another user either sold or loaned, you **MUST** pass on this user manual. This will make sure that all other users can use and maintain this machine safely.

Environmental Protection

1. Environmental protection should be a priority of considerable importance when using the machine, for the benefit of both social coexistence and the environment in which we live. Try not to cause any disturbance to the surrounding area.
2. You must comply with local regulations and provisions for the disposal of packaging, oils, fuel, filters, damaged parts or any elements which have a strong impact on the environment. This waste must not be disposed of as normal waste. It needs to be separated and taken to specified waste disposal centres where the material will be recycled.
3. You must comply with local regulations for the disposal of waste materials after mowing.
4. When disposing, do not pollute the environment with the machine, but hand it over to a disposal centre, in accordance with the local laws in force.

EU Declaration Of Conformity

Importer and Authorised Representative

Genpower Ltd
Isaac Way, Pembroke Dock, SA72 4RW

Country of Origin: China

Description: 1600W Sweeper

SKU Code: HYSW1600E

Date of Issue: 09/06/2021

Regulations and Directives of Compliance

- 2006/42/EC The Machine Directive
- 2014/30/EU EMC Directive
- 2000/14/EC Noise Emissions
- 2011/65/EU RoHS

Statement of Declaration

We the importer and authorised representative of the product described confirm conformity within the provisions of applicable regulations and directives listed within this document.

Signed on Behalf of Genpower Ltd

Place of Issue: Genpower Ltd

Signatory Name: Roland Llewellyn

Position: Managing Director

R J Llewellyn
.....



Notes

Notes

Useful Information

Check Out Our YouTube Channel

Our videos on YouTube include:

- Unboxing
- Assembly of your machine
- How to service your machine
- Products in use
- 'How To' videos
- Product features

Go to YouTube and search '**Hyundai Power Products**'.

Warranty

Proof of purchase will be required before you make a warranty claim. Full warranty terms and conditions can be found on the HYUNDAI POWER PRODUCTS website:

www.hyundaipowerproducts.co.uk

Manual Updates

Our manuals are constantly being reviewed and updated. Should you find an error, omission or something unclear, please contact us for assistance. We reserve the right to make any modifications without prior notice whenever necessary. Our latest manuals are also placed online. All our manuals can be downloaded at:
www.hyundaipowerproducts.co.uk

Returning Your Product

If you are returning your product, please contact the dealer for their returns policy.

Leaving A Review

We work very hard to give all of our customers the best possible service. If you have any problems, before leaving negative feedback, please contact us to give us a chance to resolve the issue. We would be delighted if you left us positive feedback! To leave a review, please go to:

uk.trustpilot.com/review/hyundaipowerequipment.co.uk

Ordering Spare Parts

You can find the spare part you are looking for at **power-spares.co.uk**

Product Record

Information

As soon as you have purchased the machine, we recommend that you fill out the following. If you need to contact an authorised dealer or customer service for information on servicing, you may need to provide the following information.

Date Of Purchase:.....

Dealer Name:.....

Dealer Phone:.....

Model Number:.....

Serial / Batch Number:.....

Contact Us

Need Help? Talk To Our Experts

Our friendly aftersales team will be more than happy to help you.



Phone

Call our team on 01646 687 880



Email

aftersales@hyundaipowerproducts.co.uk



Online Live Chat

Go to www.hyundaipowerproducts.co.uk



Post

Genpower Ltd, Isaac Way, Pembroke Dock, Pembrokeshire, SA72 4RW.



Hyundai Support Website

Go to hyundaisupport.co.uk

HYUNDAI

POWER PRODUCTS

Importer:
GENPOWER LTD
Isaac Way, London Road,
Pembroke Dock, UK, SA72 4RW.
T: +44 (0) 1646 687 880
E: info@hyundaipowerproducts.co.uk
www.hyundaipowerproducts.co.uk

Imported / Distributed by Genpower Ltd for the United Kingdom & Ireland

Licensed by Hyundai Corporation, Korea