

**HYUNDAI**  
POWER PRODUCTS

# **PETROL PRESSURE WASHER**

**HYW2500P, HYW3000P, HYW3000P2  
HYW3100P, HYW3100P2, HYW4000P**

---

**User manual**

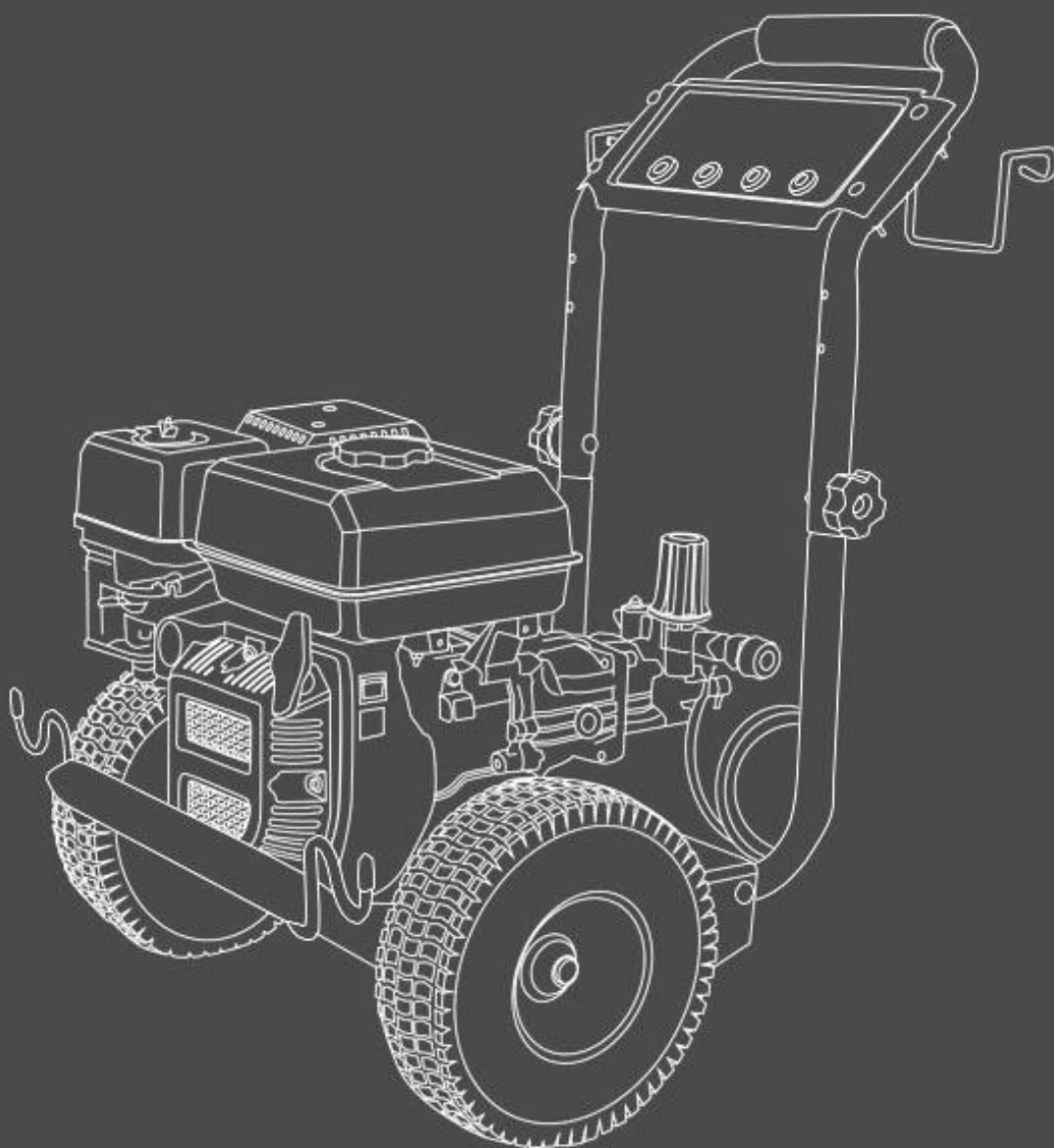



1. INTRODUCTION	3
2. PRODUCT IDENTIFICATION	4
3. SAFETY	4-9
4. PETROL WASHER COMPONENTS	10
5. ASSEMBLY	11
6. PRE-OPERATION CHECK LIST	12
7. STARTING YOUR WASHER	12-15
8. SHUTTING DOWN YOU WASHER	16
9. QUICK RELEASE NOZZLES	17-18
10. TROUBLESHOOTING	19-20
11. STORAGE	21
12. PARTS BREAKDOWN	22-29
13. MAINTENANCE	30
14. DECLARATION OF CONFORMITY	31
15. CONTACT DETAILS	32





## 1. INTRODUCTION



Attention: Read through the complete manual prior to the initial use of your pressure washer.

### 1.1. Carbon monoxide warning.

1.1.1. Carbon monoxide is a colourless and odourless gas. Inhaling this gas can cause death as well as serious long term health problems such as brain damage. The symptoms of carbon monoxide poisoning can include but not limited to the following; headaches, dizziness, nausea, breathlessness, collapsing or loss of consciousness.

1.1.2. DO NOT use in an enclosed area or a moving vehicle.



### 1.2.

#### 1.2.1. Using the operating manual.

The operating manual is an important part of your pressure washer and should be read thoroughly before initial use, and referred to often to make sure adequate safety and service concerns are being addressed.

1.2.2. Reading the instruction manual thoroughly will help avoid any personal injury or damage to your machine. The information in this manual will offer you the most effective tools for cleaning as well as the safest. By knowing how best to operate this machine you will be better positioned to show others who may also operate the unit.

1.2.3. This manual contains information for the complete range of pressure washers and is placed in an order, starting from the safety requirements, to the operating functions of your machine. You can refer back to the manual at any time to help troubleshoot any specific operating functions, so store it with the machine at all times.

### 1.3. Notice.

1.3.1. Actual pressure released at the point of discharge may vary by machine due to varying factors including: Volume of water being fed to the machine by the water source, the inclusion of a Chemical injector in the line, or variations in Engine performance.



## 2. PRODUCT IDENTIFICATION

### 2.1. Pressure Washer

- 2.1.1. If you need to contact an authorised dealer or customer service for information on servicing, always provide the product model and identification numbers. You will need to locate the model and serial number for the machine and record the information in the places provided below.

Date of purchase	
Dealer name	
Dealer phone	
Model number	
Serial number	
Engine model number	

## 3. SAFETY

### 3.1. Important safety instructions save these instructions.

- 3.1.1. **WARNING** – When using this product basic precautions should always be followed, including the following:-
- 3.1.1.1. Read all the instructions before using the product.
  - 3.1.1.2. To reduce the risk of injury, close supervision is necessary when a product is used near children.
  - 3.1.1.3. Know how to stop the product and bleed pressures quickly. Be thoroughly familiar with the controls.
  - 3.1.1.4. Stay alert – watch what you are doing.
  - 3.1.1.5. Do not operate the product when fatigued or under the influence of alcohol or drugs.
  - 3.1.1.6. Keep operating area clear of all persons
  - 3.1.1.7. Do not overreach or stand on unstable support. Keep good footing and balance at all times. Follow the maintenance instructions specified in the manual.

### 3.2. Safety Labels

The machine safety label shown below is placed on your machine to draw attention to potential safety hazards.

#### **WARNING!**



Do not leave unit running longer than 1 minute without using or the pump will overheat

Do not use pressure washer in enclosed space without ventilation. Carbon Monoxide kills.



Do not let unit freeze.



Always wear eye protection.



High pressure sprays can cause serious bodily injury. Use with Caution.



Warranty is void if you exceed the pre-set pressure causing severe damage to pump and unloader.



### 3.3. SAFETY RULES



This is the safety alert symbol. It is used to alert you to potential personal injury hazards. Obey all safety messages that follow this symbol to avoid possible injury or death. The safety alert symbol (▲) is used with a signal word (DANGER, CAUTION, WARNING), a pictorial and/or a safety message to alert you to hazards. Follow the maintenance instructions specified in the manual.

3.3.1. **WARNING** - Indicates a hazard which, if not avoided, could result in death or serious injury.

3.3.2. **CAUTION** - Indicates a hazard which, if not avoided, might result in minor or moderate injury.

3.3.3. **NOTICE** - Indicates a situation that could result in equipment damage. Follow safety messages to avoid or reduce the risk of injury or death.



EXPLOSION



FIRE



ELECTRICSHOCK



TOXICFUMES



KICKBACK



HOTSURFACE



FLYINGOBJECTS



SLIPPERY



FALL



FLUID INJECTION



MOVING PARTS



READ MANUAL

3.3.5.  **WARNING** Risk of electrocution, contact with power source can cause electric shock or burns.



**WARNING** Fuel and its vapours are extremely flammable and explosive.



**WARNING** Fire or explosion can cause severe burns or death.



### **3.3.7.1. When Adding or Draining Fuel**

- 3.3.7.1.1. Turn pressure washer OFF and let it cool at least 2 minutes before removing fuel cap. Loosen cap slowly to release pressure in tank.
- 3.3.7.1.2. Fill or drain fuel tank outdoors.
- 3.3.7.1.3. DO NOT overfill tank. Allow space for fuel expansion (25mm from top).
- 3.3.7.1.4. If fuel spills, wait until it evaporates before starting engine.
- 3.3.7.1.5. Keep fuel away from sparks, open flames, pilot lights, heat, and other ignition sources.
- 3.3.7.1.6. DO NOT light a cigarette or smoke.

### **3.3.7.2. When Starting Equipment**

- 3.3.7.2.1. Ensure spark plug, exhaust, fuel cap, and air cleaner are in place.
- 3.3.7.2.2. DO NOT crank engine with spark plug removed.

### **3.3.7.3. When Operating Equipment**

- 3.3.7.3.1. DO NOT tip engine or equipment at angle which causes fuel to spill.
- 3.3.7.3.2. DO NOT spray flammable liquids.

### **3.3.7.4. When Transporting or Repairing Equipment**

- 3.3.7.4.1. Transport/repair with fuel tank EMPTY or with fuel shutoff valve OFF.
- 3.3.7.4.2. Disconnect spark plug wire.

### **3.3.7.5. When Storing Fuel or Equipment with Fuel in Tank**

- 3.3.7.5.1. Store away from furnaces, stoves, water heaters, clothes dryers, or other appliances that have pilot light or other ignition source because they can ignite fuel vapours.



3.3.8.



**WARNING** Engine exhaust fumes contain carbon monoxide, an odourless, colourless, poison gas. Breathing carbon monoxide can cause headache, fatigue, dizziness, vomiting, confusion, seizures, nausea, fainting or death. Some chemicals or detergents may be harmful if inhaled or ingested, causing severe nausea, fainting, or poisoning.

3.3.8.1.

ONLY operate pressure washer outdoors.

3.3.8.2.

Do not allow exhaust gas from entering a confined area through windows, doors, ventilation intakes or other openings.

3.3.8.3.

DO NOT start or run engine indoors or in an enclosed area, even if windows and doors are open.

3.3.8.4.

Use a respirator or mask whenever there is a chance that vapours may be inhaled.

3.3.8.5.

Read all instructions with the mask so you are certain the mask will provide the necessary protection against inhaling harmful vapours.

3.3.9.



**WARNING** Starter cord kickback (rapid retraction) can result in bodily injury.

Kickback will pull hand and arm toward engine faster than you can let go. Broken bones, fractures, bruises, or sprains could result.

3.3.9.1.

NEVER pull starter cord without first releasing spray gun pressure.

3.3.9.2.

When starting engine, pull cord slowly until resistance is felt and then pull rapidly to avoid kickback.

3.3.9.3.

After each starting attempt, where engine fails to run, always point spray gun in safe direction and squeeze spray gun trigger to release high pressure.

3.3.9.4.

Firmly grasp spray gun with both hands when using high pressure spray to avoid injury when spray gun kicks back.

3.3.10.



**WARNING** Use of pressure washer can create puddles and slippery surfaces.

3.3.11.



**WARNING** Kickback from spray gun can cause you to fall.

3.3.11.1.

Operate pressure washer from a stable surface.

3.3.11.2.

The cleaning area should have adequate slopes and drainage to reduce the possibility of a fall due to slippery surfaces.

3.3.11.3.

Be extremely careful if you must use the pressure washer from scaffolding or any other similar location.

3.3.11.4.

Firmly grasp spray gun with both hands when using high pressure spray to avoid injury when spray gun kicks back.





3.3.12.



**WARNING** Contact with exhaust area can result in serious burns.

3.3.13.



**WARNING** Exhaust heat/gases can ignite combustibles, structures or damage fuel tank causing a fire.

3.3.13.1.

DO NOT touch hot parts and AVOID hot exhaust gases. Allow

3.3.13.2.

equipment to cool before touching.

3.3.13.3.

Keep at least 5 feet (1.5 m) of clearance on all sides of pressure washer including overhead.

3.3.14.



**WARNING** Risk of eye injury. Spray can splash back or propel objects.

3.3.14.1.

Always wear safety goggles when using this equipment or in vicinity of where equipment is in use.

3.3.14.2.

Before starting the pressure washer, be sure you are wearing adequate safety goggles.

3.3.14.3.

NEVER substitute safety glasses for safety goggles.

3.3.15.



**WARNING** The high pressure stream of water that this equipment produces can cut through skin and its underlying tissues, leading to serious injury and possible amputation. Spray gun traps high water pressure, even when engine is stopped and water is disconnected, which can cause injury.

3.3.15.1.

DO NOT allow CHILDREN to operate pressure washer.

3.3.15.2.

NEVER repair high pressure hose. Replace it.

3.3.15.3.

NEVER repair leaking connections with sealant of any kind. Replace O- ring or seal.

3.3.15.4.

NEVER connect high pressure hose to nozzle extension.

3.3.15.5.

Keep high pressure hose connected to pump and spray gun while system is pressurised.

3.3.15.6.

ALWAYS point spray gun in safe direction and squeeze spray gun trigger, to release high pressure, every time you stop engine.

3.3.15.7.

NEVER aim spray gun at people, animals, or plants.

3.3.15.8.

DO NOT secure spray gun in open position.

3.3.15.9.

DO NOT leave spray gun unattended while machine is running.

3.3.15.10.

NEVER use a spray gun which does not have a trigger lock or trigger guard in place and in working order.

3.3.15.11.

Always be certain spray gun, nozzles and accessories are correctly attached.







3.3.16.



**WARNING** Starter and other rotating parts can entangle hands, hair, clothing or accessories.

3.3.16.1. NEVER operate pressure washer without protective housing or covers.

3.3.16.2. DO NOT wear loose clothing, jewellery or anything that may be caught in the starter or other rotating parts.

3.3.16.3. Tie up long hair and remove jewellery.

3.3.17.



**WARNING** Unintentional sparking can result in fire or electric shock.

3.3.17.1. When Adjusting or Making Repairs to Your Pressure Washer

3.3.17.1.1. Disconnect the spark plug cap from the spark plug and place it where it cannot contact spark plug.

3.3.17.1.2. **When Testing for Engine Spark**

3.3.17.2.1. Use approved spark plug tester.

3.3.17.2.2. DO NOT check for spark with spark plug removed.

3.3.18. **NOTICE** High pressure spray may damage fragile items including glass.

3.3.18.1. DO NOT point spray gun at glass when using red 0° spray tip.

3.3.18.2. NEVER aim spray gun at plants.

3.3.19. **NOTICE** Improper treatment of pressure washer can damage it and shorten its life.

3.3.19.1. If you have questions about intended use, ask your dealer or contact nearest authorised dealer.

3.3.19.2. NEVER operate units with broken or missing parts, or without protective housing or covers.

3.3.19.3. DO NOT by-pass any safety device on this machine.

3.3.19.4. DO NOT tamper with governed speed.

3.3.19.5. DO NOT operate pressure washer above rated pressure.

3.3.19.6. DO NOT modify pressure washer in any way.

3.3.19.7. Before starting pressure washer in cold weather, check all parts of the equipment to be sure ice has not formed there.

3.3.19.8. NEVER move machine by pulling on hoses. Use handle provided on unit.

3.3.19.9. Check fuel system for leaks or signs of deterioration, such as chafed or spongy hose, loose or missing clamps, or damaged tank or cap. Correct all defects before operating pressure washer.





## 4. PRESSURE WASHER COMPONENTS

Read this operating manual and safety rules before operating your pressure washer.



<p><b>1. Nozzles</b> Detergent, 0°, 15°, 40° &amp; Turbo Nozzle: for high pressure cleaning applications.</p>	<p><b>2. High Pressure Hose Connect</b> one end to water pump and the other end to spray gun.</p>	<p><b>3. Pressure Control Knob</b> Varies pressure of high pressure spray.</p>	<p><b>4. Water Inlet</b> Connection for garden hose.</p>	<p><b>5. High Pressure Outlet Connection</b> for high pressure hose.</p>
<p><b>6. Pump</b> Develops high pressure.</p>	<p><b>7. Oil Level Indicator</b> Level should be at halfway</p>	<p><b>8. Choke Lever</b> Prepares a cold engine for starting.</p>	<p><b>9. Fuel Valve</b> used to turn fuel supply on and off to engine.</p>	<p><b>10. Recoil Starter</b> Used for starting the engine manually.</p>
<p><b>11. Throttle Lever</b> Sets engine in starting mode for pull starter.</p>	<p><b>12. Engine Switch</b> Set switch to "On" for pull starting. Set switch to "Off" to stop a running engine.</p>	<p><b>13. Air Filter</b> Protects engine by filtering dust and debris out of air intake.</p>	<p><b>14. Fuel Tank</b> Fill tank with regular unleaded fuel. Always leave room for fuel expansion (25mm from top)</p>	
<p><b>15. Spray Gun Extension</b> with Quick Connect Nozzles Controls the application of water onto cleaning surface with trigger device. Includes trigger lock. Allows you to switch between five different nozzles.</p>				



## 5. ASSEMBLY

- 5.1. Your pressure washer requires some assembly and is ready for use after it has been properly filled with both the recommended oil and fuel.

5.2. If you have any problems with the assembly of your pressure washer, please call the help line. If calling for assistance, please have the model and serial number from the data tag available.

### 5.3. Unpack the Pressure Washer

- 5.3.1. Remove the parts bag, accessories, and inserts included with pressure washer.  
5.3.2. Remove machine from box.  
5.3.3. Ensure you have all included items prior to assembly.

### 5.4. Attach Handle

- 5.4.1. Place handle (A) onto handle supports (B) connected to main unit. Make sure holes (C) in handle align with holes on handle supports.

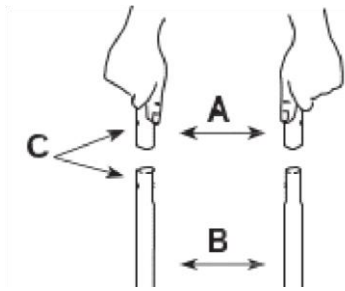

- 5.5. **NOTE** It may be necessary to move the handle supports from side to side in order to align the handle so it will slide over the handle supports.

- 5.6. Insert carriage bolts through holes from outside of unit and attach a plastic knob from inside of unit. Tighten by hand.

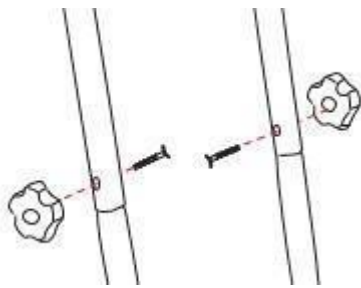

- 5.7. Insert multi coloured quick connect spray tips and other supplied accessories in spaces provided on handle.

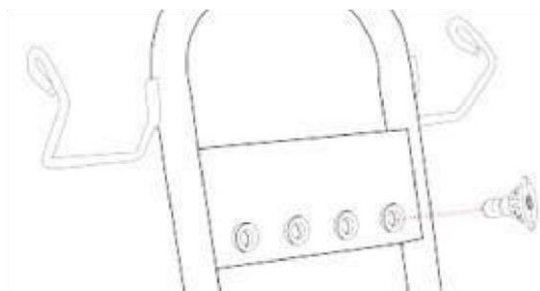



## 6. PRE OPERATION CHECK LIST

- 6.1. Follow the Checklist Below Prior to Using the Machine Each Time
  - 6.1.1. Check to ensure the engine oil is at the proper level.
  - 6.1.2. Use SAE 15W40 Oil
  - 6.1.3. Check the 2 handle knobs to ensure they are tight and will not vibrate loose.
  - 6.1.4. Add fuel to the petrol tank - Regular Unleaded Petrol
  - 6.1.5. Connect and tighten the garden hose to the garden hose attachment.

**NOTE** Water must be turned on prior to starting the washer, pull the spray trigger to ensure water is moving through the lines and out the nozzle without any leaks before starting the unit.

- 6.1.6. Review the safety guidelines in the manual prior to starting the unit.
- 6.1.7. If you have any issues operating the pressure washer, call after sales on 01646 687880.

6.2. **WARNING** Always check the level of the engine and pump oil prior to starting the washer.

6.2.1.  Failure to do so could cause the engine and pump to seize if the oil is low or empty.

6.3.  **WARNING** Connect hose and water supply to pump before starting. DO NOT start your pressure washer without the water supply turned on.

6.3.1. Failure to do so will result in damaging the pump from overheating and void the warranty.

## 7. STARTING YOUR WASHER

7.1. To start your pressure washer for the first time, follow these instructions step-by-step. This starting information also applies if you have let the pressure washer sit idle for at least a day.

7.1.1. Place pressure washer near an outside water source capable of supplying water at a flow rate greater than 14.4 litres per minute and no less than 20 PSI at pressure washer end of garden hose. DO NOT siphon supply water.

7.1.2. Make sure unit is in a level position.

7.1.3. Connect garden hose to water inlet on pressure washer pump.

7.2. **NOTE** DO NOT run the pump without the water supply connected and turned on.

7.3. Attach wand extension to spray gun and tighten by hand.

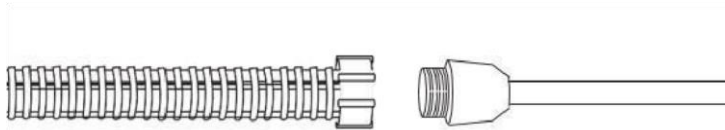



- 7.4. Choose desired nozzle, pull back nozzle extension collar, insert nozzle and release collar. Tug on nozzle to make sure it is securely in place. See Nozzle Selection Section.

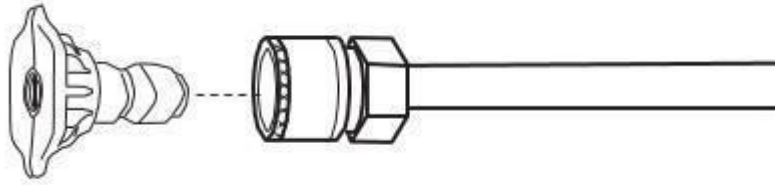

- 7.5. Uncoil high pressure hose and attach quick connect end of hose to base of spray gun. Pull down on collar of quick connect, slide onto spray gun and let go of collar. Tug on hose to be sure of tight connection. Some models may use a threaded hose connector.

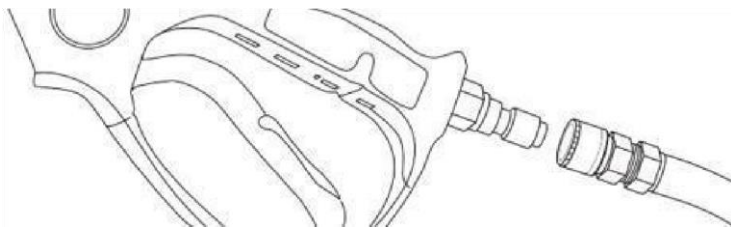

- 7.6. **WARNING** The high pressure stream of water that this equipment produces can cut through skin and its underlying tissues, leading to serious injury and possible amputation.



- 7.6.1. NEVER connect high pressure hose to nozzle extension.  
 7.6.2. Keep high pressure hose connected to pump and spray gun while system is pressurized.  
 7.6.3. Always be certain spray gun, nozzles and accessories are correctly attached.

- 7.7. Attach other end of high pressure hose to high pressure outlet (A) on pump.  
 Pull down on collar of quick connect, slide onto pump and let go of collar. Pull on hose to be sure of tight connection. \*Some models may use a threaded hose connector.

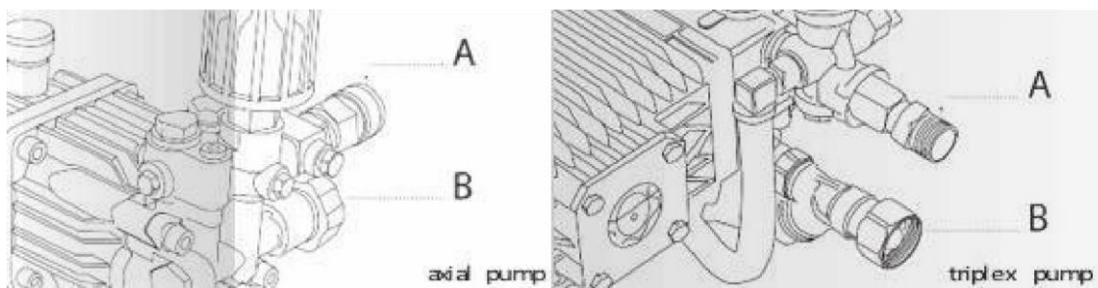

- 7.8. **NOTE** Pump Uses SAE 15W 40 Oil.  
 7.9. Turn Water Supply on, point gun in a safe direction and squeeze the trigger to purge the pump of air and debris. Do this for at least 30 seconds.



- 7.10. Take a look at all connections to make sure there are no leaks or loose connections.
- 7.11. **IMPORTANT** If drawing water from a barrel, it is advisable to have a gravity- fed supply. Use **ONLY** cold water (less than 38°C/100°F).
- 7.12. Connect the garden hose to the water inlet. Tighten by hand.
- 7.13. To start the machine, locate the engine switch on the side of the engine, and switch it to the ON position. (see component chart to locate switch) Check to ensure fuel valve is in the ON position and if starting cold apply the choke.
- 7.14. Always release water pressure by squeezing trigger gun.
- 7.15. Pull recoil cord slowly until resistance is felt and then pull rapidly to avoid kickback. Make sure to position yourself in a balanced position. **DO NOT** place hand on engine exhaust for balance, this will result in severe burns.
- 7.16. **WARNING** Running engine gives off carbon monoxide, an odourless, colourless, poison gas. Breathing carbon monoxide can cause headache, fatigue, dizziness, vomiting, confusion, seizures, nausea, fainting or death.



- 7.16.1. Operate pressure washer **ONLY** outdoors.
- 7.16.2. Keep exhaust gas from entering a confined area through windows, doors, ventilation intakes, or other openings.
- 7.16.3. **DO NOT** start or run engine indoors or in an enclosed area, even if windows and doors are open.

7.17. **IMPORTANT** Before starting the pressure washer, be sure you are wearing adequate safety goggles.

7.18. **WARNING** Risk of eye injury. Spray can splash back or propel objects.



- 7.18.1. Always wear safety goggles when using this equipment or in vicinity of where equipment is in use.
- 7.18.2. Before starting the pressure washer, be sure you are wearing adequate safety goggles.
- 7.18.3. **NEVER** substitute safety glasses for safety goggles.

7.19. **WARNING** Starter cord kickback (rapid retraction) can result in bodily injury. Kickback will pull hand and arm toward engine faster than you can let go. Broken bones, fractures, bruises, or sprains could result.



- 7.19.1. **NEVER** pull starter cord without first relieving spray gun pressure.
- 7.19.2. When starting engine, pull cord slowly until resistance is felt and then pull rapidly to avoid kickback.
- 7.19.3. After each starting attempt, where engine fails to run, always point spray gun in safe direction and squeeze spray gun trigger to release high pressure.
- 7.19.4. Firmly grasp spray gun with both hands when using high pressure spray to avoid injury when spray gun kicks back.





7.20. **WARNING** The high pressure stream of water that this equipment produces can cut through skin and its underlying tissues, leading to serious injury and possible amputation. Spray gun traps high water pressure, even when engine is stopped and water is disconnected, which can cause injury.



- 7.20.1. DO NOT allow CHILDREN to operate pressure washer.
- 7.20.2. NEVER repair high pressure hose. Replace it.
- 7.20.3. NEVER repair leaking connections with sealant of any kind. Replace O-ring or seal.
- 7.20.4. NEVER connect high pressure hose to nozzle extension.
- 7.20.5. Keep high pressure hose connected to pump and spray gun while system is pressurized.
- 7.20.6. ALWAYS point spray gun in safe direction and squeeze spray gun trigger, to release high pressure, every time you stop engine.
- 7.20.7. NEVER aim spray gun at people, animals, or plants.
- 7.20.8. DO NOT secure spray gun in open position.
- 7.20.9. DO NOT leave spray gun unattended while machine is running.
- 7.20.10. NEVER use a spray gun which does not have a trigger lock or trigger guard in place and in working order.
- 7.20.11. ALWAYS be certain spray gun, nozzles and accessories are correctly attached.

7.21. **WARNING** Contact with exhaust area can result in serious burns.

7.22. **WARNING** Exhaust heat/gases can ignite combustibles, structures or damage fuel tank causing a fire.



- 7.22.1. DO NOT touch hot parts and AVOID hot exhaust gases.
- 7.22.2. Allow equipment to cool before touching.
- 7.22.3. Keep at least 1.5m (5 feet) of clearance on all sides of pressure washer including overhead.



## 8. SHUTTING DOWN YOUR WASHER

### 8.1. **How to Shut Down Your Pressure Washer**

- 8.1.1. Release spray gun trigger and let engine idle down.
- 8.1.2. Turn the engine switch to the OFF position.
- 8.1.3. ALWAYS point spray gun in a safe direction, squeeze spray gun trigger to release retained high water pressure.

8.2. **IMPORTANT** Spray gun traps high water pressure, even when engine is stopped and water is disconnected. Couplings will not release if under pressure.

8.3. **WARNING** The high pressure stream of water that this equipment produces can cut through skin and its underlying tissues, leading to serious injury and possible amputation. Spray gun traps high water pressure, even when engine is stopped and water is disconnected, which can cause injury.



- 8.3.1. Keep high pressure hose connected to pump and spray gun while system is pressurized.
- 8.3.2. ALWAYS point spray gun in safe direction and squeeze spray gun trigger, to release high pressure, every time you stop engine.







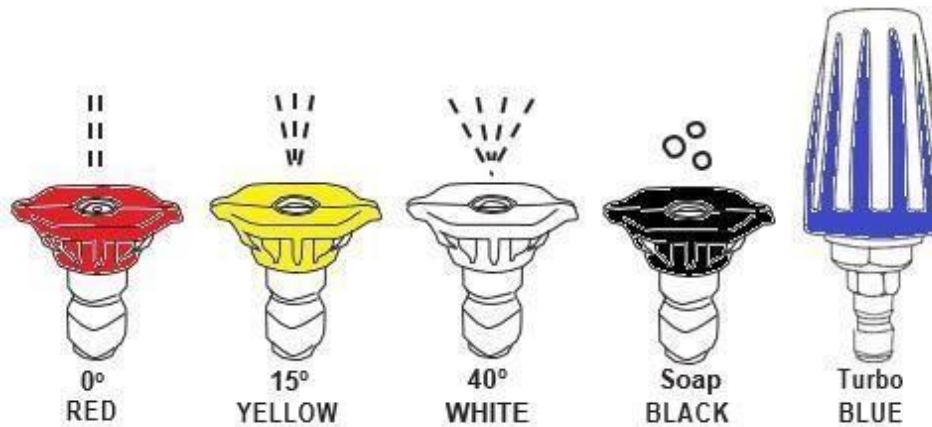

## 9. QUICK RELEASE NOZZLES

- 9.1. The quick-release on the lance allows you to switch between four different quick-release nozzles. The nozzles can be changed while pressure washer is running once spray gun trigger safety lock is engaged. The different nozzles vary the spray pattern as shown below.



- 9.2.  **WARNING** The high pressure stream of water that this equipment produces can cut through skin and its underlying tissues, leading to serious injury and possible amputation.

9.2.1. NEVER change nozzles without the trigger safety lock being engaged on the spray gun.

9.2.2. DO NOT twist nozzles whilst spraying.

9.3. Follow these instructions to change the nozzles:

9.3.1. Pull back collar on quick-connect and pull current nozzle off. Store nozzles in holder provided on the handle. Storing nozzles in the designated holder will help prevent debris clogging the tip.

9.3.2. Select desired nozzle:

9.3.2.1. For gentle rinse, select white 40° nozzle.

9.3.2.2. To scour surface, select yellow 15° or red 0° nozzle.

9.3.2.3. To apply detergent, select black nozzle.

9.3.2.4. Pull back on collar, insert new nozzle and release collar. Tug on nozzle to make sure it is securely in place.

9.4. **Usage tips.**

9.4.1. For most effective cleaning, keep nozzle from 8 to 24 inches away from cleaning surface.

9.4.2. If you get nozzle too close, especially using a high pressure nozzle, you may damage surface being cleaned.

9.5. **To apply detergent, follow these steps:**

9.5.1. Fit black soap nozzle.

9.5.2. Prepare detergent solution as required by job.

9.5.3. Place small filter end of detergent siphoning tube into detergent container.

9.5.4. **NOTE** Make sure the filter is fully submerged in detergent while applying detergent.

9.5.5. **NOTE** This washer will only draw soap with the black soaper nozzle. The White, Red, and Yellow nozzle will not draw soap.



- 9.6. Make sure black nozzle is installed.
- 9.7. Make sure garden hose is connected to water inlet. Check that high pressure hose is connected to spray gun and pump. Turn on water.
- 9.8. **NOTICE** You must attach all hoses before you start the engine.
  - 9.8.1. Starting the engine without all the hoses connected and without the water turned ON will damage the pump.
  - 9.8.2. Damage to equipment resulting from failure to follow this instruction will void the warranty.
- 9.9. **IMPORTANT** You must flush the detergent siphoning system after each use by placing the filter into a bucket of clean water, then run the pressure washer at low pressure for 1-2 minutes.
- 9.10. **CAUTION** Chemicals can cause bodily injury and/or property damage.
  - 9.10.1. NEVER use caustic liquid with pressure washer.
  - 9.10.2. Use ONLY pressure washer safe detergent/soaps. Follow all manufacturer's instructions.





## 10. TROUBLESHOOTING

- 10.1. If you are experiencing a problem that is not listed in this chart, or have checked all the possible cause listed and you are still experiencing the problem, contact Aftersales on 01646 687880.
- 10.2. Petrol engine trouble shooting.

Problem	Cause	Correction
Unit has following problems: Failure to produce pressure, erratic pressure, chattering, loss of pressure, low water volume.	<ol style="list-style-type: none"> <li>1. Low pressure spray tip installed.</li> <li>2. Water inlet is blocked.</li> <li>3. Inadequate water supply.</li> <li>4. Inlet hose is kinked or leaking.</li> <li>5. Clogged inlet hose screen.</li> <li>6. Water supply is over 100°F (38°C).</li> <li>7. High pressure hose is blocked or leaks.</li> <li>8. Spray gun leaks.</li> <li>9. Spray tip is obstructed.</li> <li>10. Pump is faulty.</li> </ol>	<ol style="list-style-type: none"> <li>1. Replace with high pressure spray tip.</li> <li>2. Clear inlet.</li> <li>3. Provide adequate water flow.</li> <li>4. Straighten inlet hose, patch leak.</li> <li>5. Check and clean inlet hose screen.</li> <li>6. Provide cooler water supply.</li> <li>7. Clear blocks in outlet hose.</li> <li>8. Replace spray gun.</li> <li>9. Clean spray tip.</li> <li>10. Contact local service agent.</li> </ol>
Detergent fails to mix with spray.	<ol style="list-style-type: none"> <li>1. Detergent siphoning is not submerged.</li> <li>2. Detergent siphoning tube/filter is clogged or cracked.</li> <li>3. High pressure spray tip installed.</li> </ol>	<ol style="list-style-type: none"> <li>1. Insert detergent siphoning tube into detergent.</li> <li>2. Clean or replace filter/detergent siphoning tube.</li> <li>3. Replace with low pressure spray tip.</li> </ol>
Engine lacks power.	<ol style="list-style-type: none"> <li>1. Dirty air filter.</li> </ol>	<ol style="list-style-type: none"> <li>1. Replace air filter.</li> </ol>
Engine will not start.	<ol style="list-style-type: none"> <li>1. Throttle lever on/off switch in OFF position.</li> <li>2. No fuel in engine.</li> <li>3. Worn fouled or dirty spark plug.</li> <li>4. Pressure build up in pump.</li> </ol>	<ol style="list-style-type: none"> <li>1. Turn throttle lever to ON position.</li> <li>2. Fill fuel tank or turn on fuel supply.</li> <li>3. Replace with factory recommended spark plug.</li> <li>4. Squeeze trigger on spray lance.</li> </ol>
Units with oil alert.	<ol style="list-style-type: none"> <li>1. Engine not level or engine oil level too low.</li> </ol>	<ol style="list-style-type: none"> <li>1. Place engine on level surface or fill crankcases with SAE30 or 15W40 oil.</li> </ol>
Engine runs well at no load but "bogs" down under full load.	<ol style="list-style-type: none"> <li>1. Engine speed is too slow.</li> </ol>	<ol style="list-style-type: none"> <li>1. Adjust throttle lever back to full throttle.</li> </ol>
Engine will not start; or starts and runs rough.	<ol style="list-style-type: none"> <li>1. Low oil level.</li> <li>2. Dirty air cleaner.</li> <li>3. Out of petrol.</li> <li>4. Stale petrol.</li> <li>5. Spark plug wire not connected to spark plug.</li> <li>6. Bad spark plug.</li> <li>7. Water in petrol.</li> <li>8. Over choking.</li> </ol>	<ol style="list-style-type: none"> <li>1. Fill crankcase to proper level.</li> <li>2. Clean or replace air cleaner.</li> <li>3. Fill fuel tank.</li> <li>4. Drain gas tank, fill with fresh fuel.</li> <li>5. Connect wire to spark plug.</li> <li>6. Replace spark plug.</li> <li>7. Drain gas tank, fill with fresh fuel.</li> <li>8. Open choke fully and crank engine.</li> </ol>
Engine shuts down during operation.	<ol style="list-style-type: none"> <li>1. Out of petrol.</li> <li>2. Low oil level.</li> </ol>	<ol style="list-style-type: none"> <li>1. Fill fuel tank.</li> <li>2. Fill crankcase with oil.</li> </ol>
Engine lacks power.	<ol style="list-style-type: none"> <li>1. Dirty air filter.</li> </ol>	<ol style="list-style-type: none"> <li>1. Replace air filter.</li> </ol>
Engine "putts" or falters.	<ol style="list-style-type: none"> <li>1. Choke is opened too soon.</li> </ol>	<ol style="list-style-type: none"> <li>1. Move choke to halfway position until engine runs smoothly.</li> </ol> <p>*All engine servicing to be taken to manufacturer's authorized service outlet.</p>





### 10.3. Pump troubleshooting.

<b>Problem</b>	<b>Causes</b>	<b>Correction</b>
No low pressure detergent delivery	<ol style="list-style-type: none"><li>1. Using wrong nozzle.</li><li>2. Siphon hose or filter is plugged.</li></ol>	<ol style="list-style-type: none"><li>1. Insert black soaper nozzle.</li><li>2. Unplug siphon hose.</li></ol>
Unit does not reach required pressure	<ol style="list-style-type: none"><li>1. Restricted or insufficient water supply.</li><li>2. Unsuitable or worn out nozzle.</li><li>3. Regulator set too low.</li></ol>	<ol style="list-style-type: none"><li>1. Check supply hose, faucet and inlet water filter. Must be connected to water source which provides 6GPM.</li><li>2. Replace nozzle.</li><li>3. Reset unloader by turning knob (clockwise increases pressure).</li></ol>
Thermal Relief Valve is open and discharging water from side of pump	<ol style="list-style-type: none"><li>1. Water temperature is too high.</li><li>2. Pump has operated more than 3 minutes without pulling trigger.</li></ol>	<ol style="list-style-type: none"><li>1. Use cool water only.</li><li>2. Pull trigger at least 30 seconds every 3 minutes.</li></ol>
Leak in the fittings	<ol style="list-style-type: none"><li>1. Water leak in high pressure fittings, hose or gun.</li></ol>	<ol style="list-style-type: none"><li>1. Use Teflon tape or pipe sealant to tighten hose fitting, replace hose or gun. ** If problem continues, take to your pressure washer dealer.</li></ol>
Pump oil is low	<ol style="list-style-type: none"><li>1. Normal use consumes oil over time.</li></ol>	<ol style="list-style-type: none"><li>1. To gauge the oil level, look directly into the sight glass. Oil level should always be at the centre dot. Do not overfill.</li></ol>
Oil is milky colour	<ol style="list-style-type: none"><li>1. Seals have worn from use and water has leaked in</li></ol>	<ol style="list-style-type: none"><li>1. Bring unit to local service center to have seals replaced.</li></ol>





## 11. STORAGE

- 11.1. **NOTICE** You must protect your unit from freezing temperatures.
- 11.1.1. Failure to do so will permanently damage your pump and render your unit inoperable.
- 11.1.2. Freeze damage is not covered under warranty.
- 11.2. To protect the unit from freezing temperatures:
- 11.2.1. Use Pump Saver to treat pump. This minimizes freeze damage and lubricates pistons and seals. Contact your local dealer for Pump Saver Solution.
- 11.2.2. If pump saver is not available, connect a 1 metre section of garden hose to water inlet adapter.
- 11.2.3. Pour RV-antifreeze (antifreeze without alcohol) into hose. Pull recoil handle twice. Disconnect 1 metre hose.
- 11.2.4. Store unit in a clean, dry area (heated area preferred).
- 11.3. Long term storage.
- 11.3.1. If you do not plan to use the pressure washer for more than 30 days, you must prepare the engine and pump for long term storage.
- 11.4. **Protect Fuel System**
- 11.4.1. Fuel Additive:
- 11.4.2. Fuel will become stale when stored over 30 days. Stale fuel causes acids and gum deposits to form in the fuel system or on essential carburetor parts. Prior to storage, if petrol has not been treated with a fuel stabilizer, it must be drained from the engine into an approved container. Then run engine until it stops from lack of fuel. When fuel stabilizers are used according to their instructions, there is no need to drain the petrol from the engine prior to storage. Run the engine for a short time to circulate stabilizer throughout the fuel system. Engine and fuel can then be stored up to 24 months.
- 11.4.3. If petrol is drained, the use of a fuel stabilizer in the storage container is still recommended to maintain freshness.
- 11.5. **NOTICE** You must protect your unit from freezing temperatures.
- 11.5.1. Failure to do so will permanently damage your pump and render your unit inoperable.
- 11.5.2. Freeze damage is not covered under warranty.
- 11.6. **Other storage tips.**
- 11.6.1. DO NOT store fuel from one season to another unless it has been treated as described in Protect Fuel System.
- 11.6.2. Replace fuel container if it starts to rust. Rust and/or dirt in fuel can cause problems if it's used with this unit.
- 11.6.3.  Cover unit with a suitable protective cover that does not retain moisture.
- 11.6.4.  **WARNING** Storage covers can be flammable.
- 11.6.4.1. DO NOT place a storage cover over a hot pressure washer.
- 11.6.4.2. Let equipment cool for a sufficient time before placing the cover on the equipment.
- 11.6.5. Store unit in a clean and dry area.



## 12. PARTS BREAKDOWN

**NOTE** Pressure washer HYW3100P (uses same pump and engine as the HYW2500P but with traditional style frame like HYW4000P).

**NOTE** Pressure washer HYW3100P2 (which uses the same pump and engine as the HYW3000P but with the traditional style frame like the HYW4000P).

### 12.1. Pressure Washer (HYW2500P).

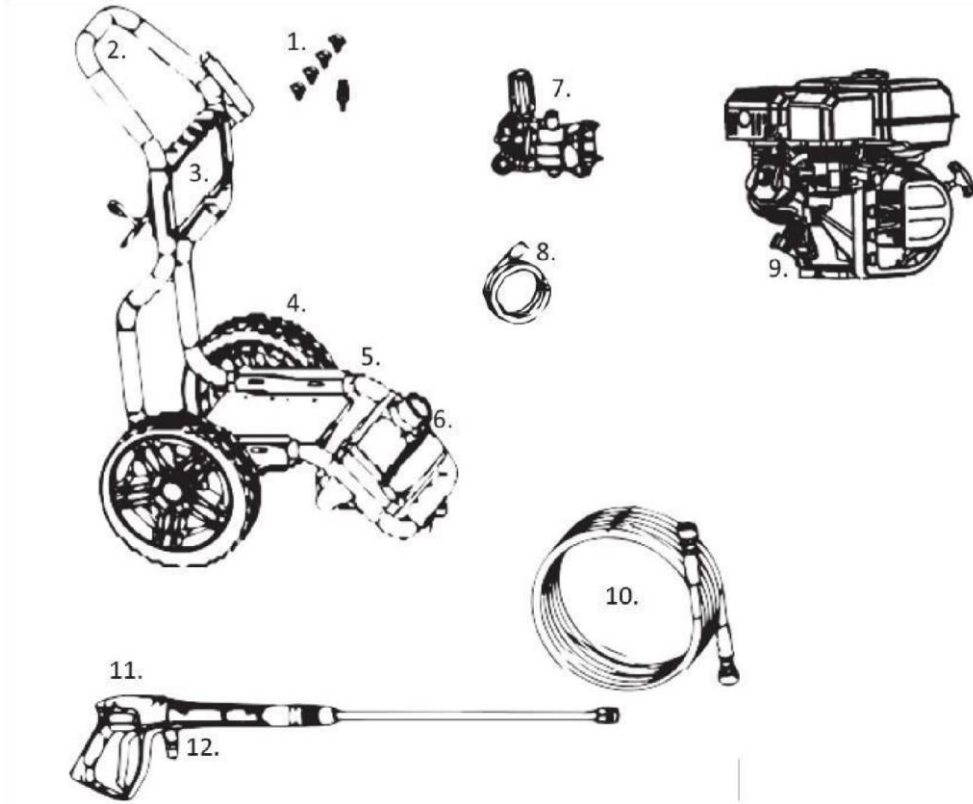

No.	Part Code	Description	Qty.
1	85.201.025	QR Nozzle 0° - 0.25	1
	85.216.025	QR Nozzle 15° - 0.25	1
	85.241.025	QR Nozzle 40° - 0.25	1
	85.266.401	Brass Soap Nozzle	1
	RJ-3030-CS	Turbo Nozzle	1
2	85.600.122-0.2	Handle Assembly	1
3	85.600.122-02.3	Decal Plate	1
4	85.600.122-05	Wheel Kit	2
5	85.600.122-03	Base Plate	1
6	85.600.122-06	Soap Container Kit	1
7	RMV2.5G30D	Axial Pump	1
8	85.400.005	Soap Hose Assembly - 1m	1



9	DH1003	Hyundai Engine - HY210	1
10	DN1059	Hose 1/4" - 10m	1
11	AC1020	Trigger Gun - 3200PSI	1
12	85.300.133	Plug 3/8MNPT x M22	1

12.2. Pressure Washer (HYW4000P).

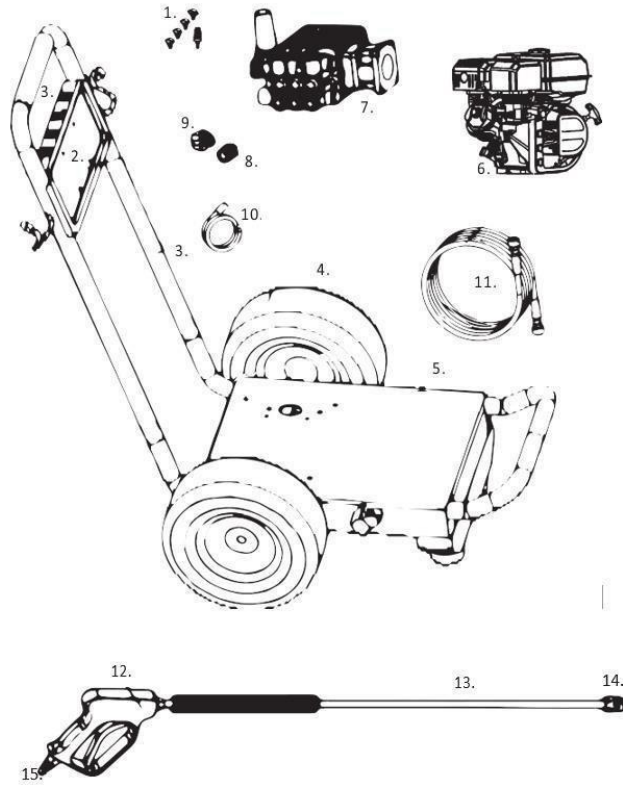

No.	Part Code	Description	Qty.
1	85.201.025	QR Nozzle 0° - 0.25	1
	85.216.025	QR Nozzle 15° - 0.25	1
	85.241.025	QR Nozzle 40° - 0.25	1
	85.266.401	Brass Soap Nozzle	1
	THA-15	Turbo Nozzle	1
2	85.600.125-02.2	Decal Plate	1
3	85.600.125-02R2	Handle Assembly	1
4	85.660.050B	12" Wheel	2
5	85.600.125-01R3	Frame Sub Assembly	1
6	DH1004	Hyundai Engine - HY420	1
7	RSV4G40	AR Triplex Pump	1
8	85.300.119	Adaptor Kit 3/8" Male	1
9	85.300.102	Coupler 1/4" QD Female	1





10	85.400.005	Soap Hose Assembly - 1m	1
11	DN1028	HP Rubber Hose - 15m	1
	85.300.103	Coupler 3/8" QD Female	1
	85.300.104	Plug 3/8 Female (Steel)	1
12	85.202.108	Trigger Gun 5000PSI	1
13	85.202.026	Wand 38" Molded GR	1
14	85.300.102	Coupler 1/4" QD Female	1
15	85.300.105	Plug 3/8" MNPT (Steel)	1







12.3. Pressure Washer Pump (HYW2500P).

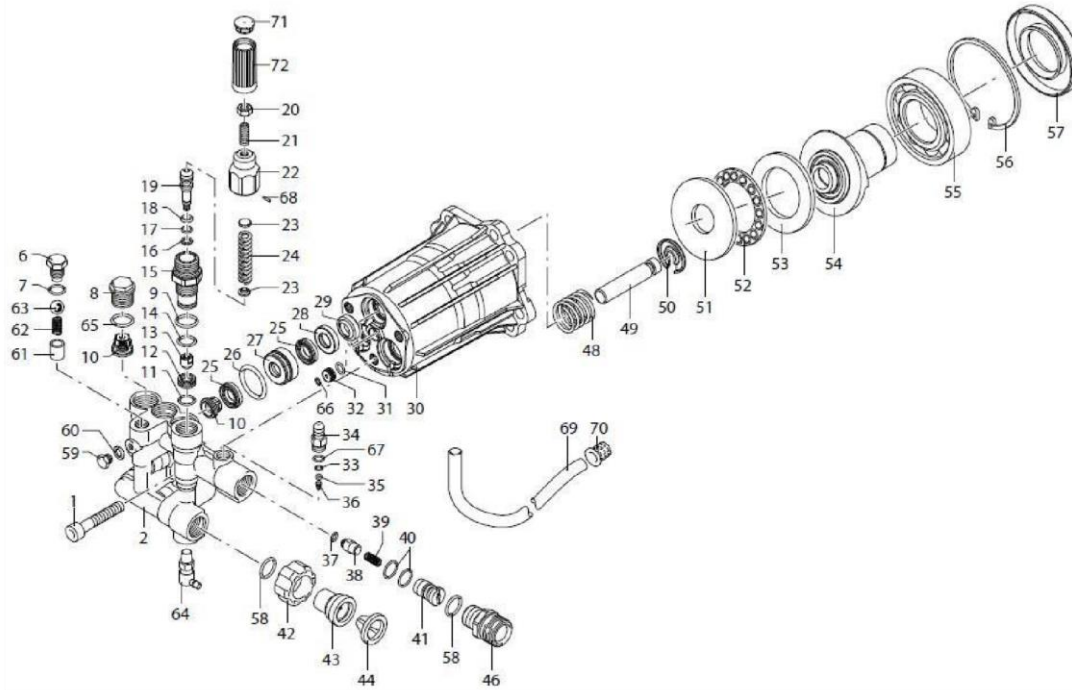

Pos	Code	Description	Qty	Pos	Code	Description	Qty
1	800220	Screw	3	38	3700220	Valve	1
2	2841620	Head	1	39	3700210	Spring	1
6	2840830	Screw	1	40	800560	O-ring	2
7	600180	O-ring	1	41	3700200	Injector	1
8	2841530	Plug	3	42	2841220	Fitting	1
9	740290	O-ring	1	43	2841230	Fitting	1
10	2849050	Complete valve	6	44	1266330	Filter	1
11	1470210	O-ring	1	46	2841120	Fitting	1
12	2841080	Seat	1	48	2840060	Spring	3
13	2840760	Shutter	1	49	2840530	Piston	3
14	820510	O-ring	1	50	2840050	Lock	3
15	2840960	Piston guide	1	51	1980130	Fifth wheel	1
16	2760210	Ring	1	52	1980250	Fifth wheel	1
17	660190	O-ring	1	53	1980240	Fifth wheel	1
18	2260100	O-ring	1	54	2840730	Wobble plate	1
19	2841140	Piston	1	55	161060	Bearing	1
20	1060120	Nut	1	56	161050	Ring	2
21	2840970	Screw	1	57	2841050	Ring	1
22	1980390	Insert	1	58	2840890	O-ring	2
23	1980220	Wobble plate	2	59	2840450	Plug	1
24	2790410	Spring	1	60	480650	Washer	1
25	2200141	Water seal	6	61	2840441	Seat	1
26	770590	O-ring	3	62	2840450	Spring	1
27	2840550	Bush	3	63	1060100	Ball	1
28	2840540	Bush	3	64	2761380	Valve	1
29	1683500	Oil seal	3	65	2841520	O-ring	3
30	2840231	Pump body	1	66	3400650	Plug	1
31	480560	O-ring	1	67	3700250	O-ring	1
32	2840710	Plug	1	68	1080070	Pin	1
33	480480	O-ring	1	69	1262790	Detergent hose	1
34	3700240	Hose tail	1	70	2000230	Filter	1
35	150280	Ball	1	71	1981770	Plug	1
36	1560520	Spring	1	72	1981780	Knob	1
37	1460431	O-ring	1				

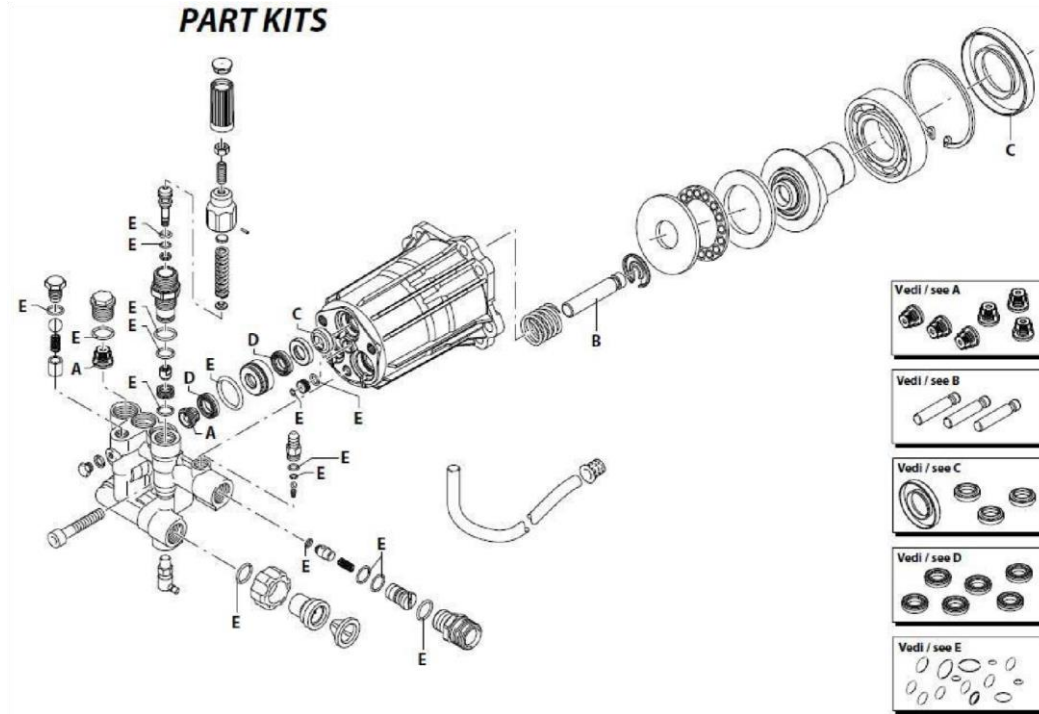

A = KIT 42123 VALVES		E = KIT 42701 O-RINGS		E = KIT 42701 O-RINGS	
POS	QTY	POS	QTY	POS	QTY
10	6	7	1	33	1
<b>B = KIT 42161 PISTONS</b>		9	1	37	1
POS	QTY	11	1	40	2
49	3	17	1	58	2
<b>C = KIT 42127 OIL SEALS</b>		18	1	65	3
POS	QTY	26	3	66	1
29	3	31	1	67	1
57	1				
<b>D = KIT 2235 OIL SEALS</b>					
POS	QTY				
25	6				



1:

**PART KITS**

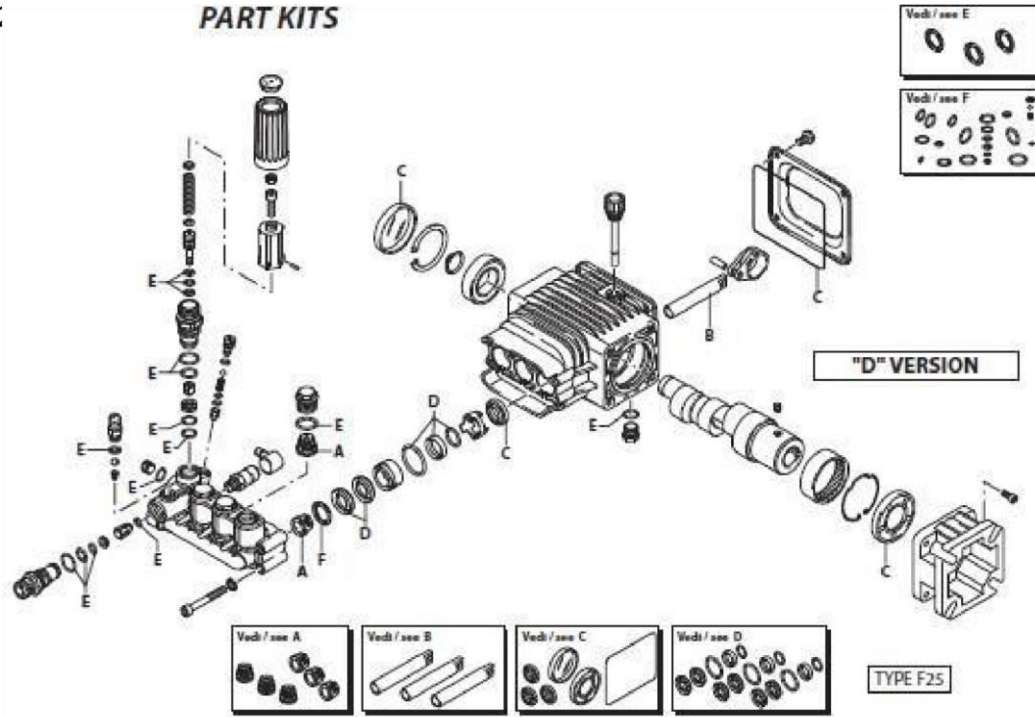

A = KIT 2186 VALVES				E = KIT 2190 O-RINGS				ty						
1	POS 60120	Nut	QTY 1	27	POS 801080	Screw	QTY 8	55	POS 802190	Screw	QTY 4			
2	3840970	Screw	6	1	28	71381550	Washer	1	8	56	27601110	Rear cover	1	
<b>B = KIT 2187 PISTONS</b>				29	82761050	Head	1	1	58	27	1321190	Bearing	1	
4	POS 80220	Plate spring	QTY 2	33	9880581	Plug	1	1	59	26	1321080	Snap ring	1	
	51		3	34	11		4	3	62	83				
<b>C = KIT 2188 OIL SEALS</b>				34	12	2760180	Plug	2	3	62	85	2769224	Pump head pre-ass	1
6	POS 44	Valve piston	QTY 3	1	35	15		6	64	86	480671	Seal	3	4
	4060100	O-Ring	1	1	<b>F = KIT 2191 SUPPORT RINGS</b>				66	180030	Screw	1		
8	560190	O-Ring	1	1	37	POS 342761	Gasket	QTY 3	67	820440	Grub screw	1		
9	0960210	Ring	1	1	38	30981580	Ring	3	3	69	1781200	Hollow shaft	1	
<b>D = KIT 2235 WATER SEALS</b>				39	1981570	Piston guide	3	71	1780580	Gas engine flange	1			
10	POS 700570	Piston guide	QTY 1	40	770260	O-Ring	3	72	2760900	Plug	1			
11	3200690	O-Ring	3	4	41	1260440	Gasket	3	73	480560	O-Ring	1		
12	304280	O-Ring	3	2	42	640070	O-Ring	3	74	1982240	Ball	1		
13	4060070	By-pass jet	3	1	43	2760310	Spacer	3	75	2761060	Spring	1		
14	4760980	Seat	3	1	44	1260460	Seal	3	76	2761040	O-Ring	1		
15	470140	O-Ring	3	1	45	2760780	Pump body	1	77	1540840	O-Ring	1		
16	1982520	Hose tail	1	46	1266740	Cap	1	78	2760890	Seat	1			
17	480480	O-Ring	1	47	1260790	Circlip	1	79	2761380	Thermic valve	1			
18	1250280	Ball	1	48	1780550	Snap ring	1	80	1080070	Pin	1			
19	1560520	Spring	1	49	1780490	Bearing	1	81	1981770	Knob plug	1			
20	2760230	Detergent injector	1	50	880130	Oil cap	1	82	1981780	Knob	1			
21	2760270	O-Ring	1	51	2760040	Piston	3	83	740290	O-Ring	1			
22	1470210	O-Ring	1	52	1780050	Piston pin	3	84	1980740	Plug	1			
23	2760120	Detergent injector	1	53	1780040	Aluminum con rod	3	85	820510	O-Ring	1			
23	2760240	Detergent injector	1	54	2760281	Gasket	1	86	2760640	Ring	1			
25	2760130	Jet	1											
26	2101770	O-Ring	1											





## 12.5. Annovi Reverberi Pump HYW4000P.

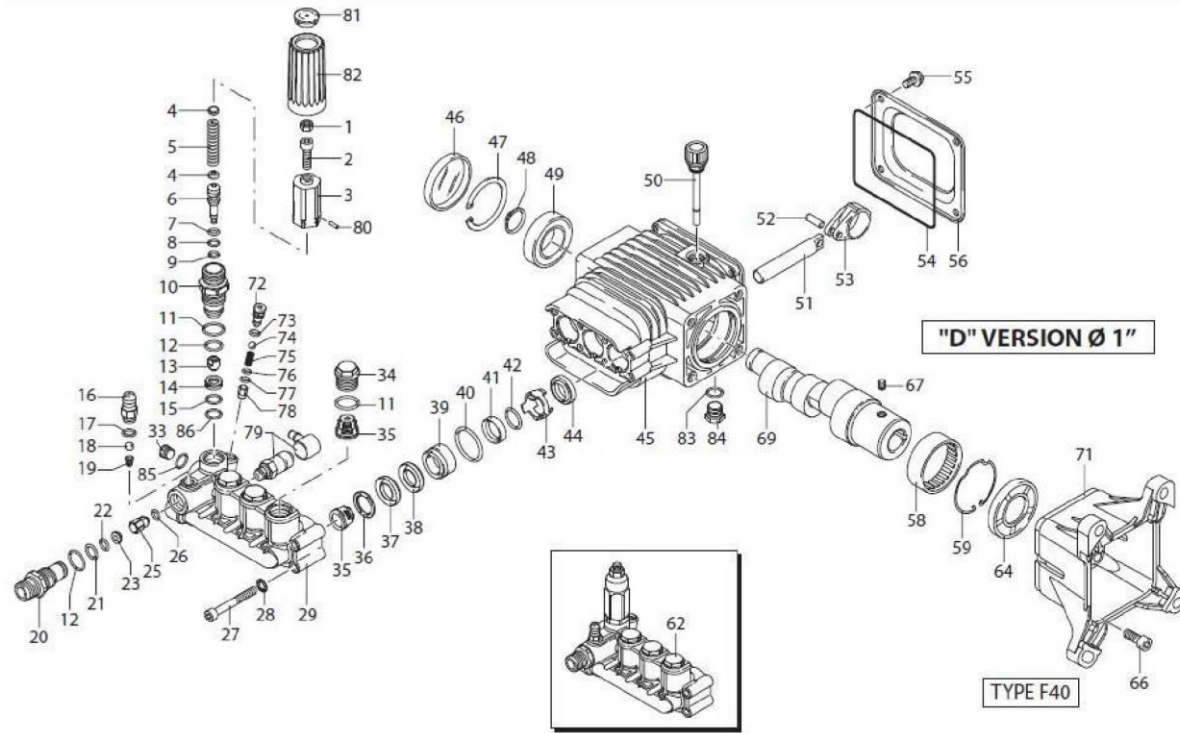

Pos	Code	Description	Qty	Pos	Code	Description	Qty	Pos	Code	Description	Qty
1	1060120	Nut	1	28	1381550	Washer	8	58	1321190	Bearing	1
2	2840970	Screw	1	29	2761050	Head	1	59	1321080	Snap ring	1
3	1980390	Handle insert	1	33	880581	Plug	1	62	2769225	Pump head pre-ass.	1
4	1980220	Plate spring	2	34	2761450	Plug	3	64	480671	Seal	1
5	2760410	Spring	1	35	2769054	Complete valve	6	66	180030	Screw	4
6	2760400	Valve piston	1	36	2760220	Support ring	3	67	820440	Grub screw	1
7	2260100	O-Ring	1	37	1342761	Gasket	3	69	1780330	Hollow shaft	1
8	660190	O-Ring	1	38	1981580	Ring	3	71	2760290	Gas engine flange	1
9	2760210	Ring	1	39	1981570	Piston guide	3	72	2760900	Plug	1
10	2760570	Piston guide	1	40	770260	O-Ring	3	73	480560	O-Ring	1
11	1200690	O-Ring	4	41	1260440	Gasket	3	74	1982240	Ball	1
12	394280	O-Ring	2	42	640070	O-Ring	3	75	2761060	Spring	1
13	2260070	By-pass jet	1	43	2760310	Spacer	3	76	2761040	O-Ring	1
14	2760980	Seat	1	44	1260460	Seal	3	77	1540840	O-Ring	1
15	770140	O-Ring	1	45	2760780	Pump body	1	78	2760890	Seat	1
16	1982520	Hose tail	1	46	1266740	Cap	1	79	2761380	Thermic valve	1
17	480480	O-Ring	1	47	1260790	Circlip	1	80	1080070	Pin	1
18	1250280	Ball	1	48	1780550	Snap ring	1	81	1981770	Knob plug	1
19	1560520	Spring	1	49	1780490	Bearing	1	82	1981780	Knob	1
20	2760230	Detergent injector	1	50	880130	Oil cap	1	83	740290	O-Ring	1
21	2760270	O-Ring	1	51	2760040	Piston	3	84	1980740	Plug	1
22	1470210	O-Ring	1	52	1780050	Piston pin	3	85	880510	O-Ring	1
23	2760120	Injector insert	1	53	1780710	Bronze con rod	3	86	2760640	Ring	1
25	2760130	Jet	1	54	2760281	Gasket	1				
26	2101770	O-Ring	1	55	802190	Screw	4				
27	801080	Screw	8	56	2760110	Rear cover	1				



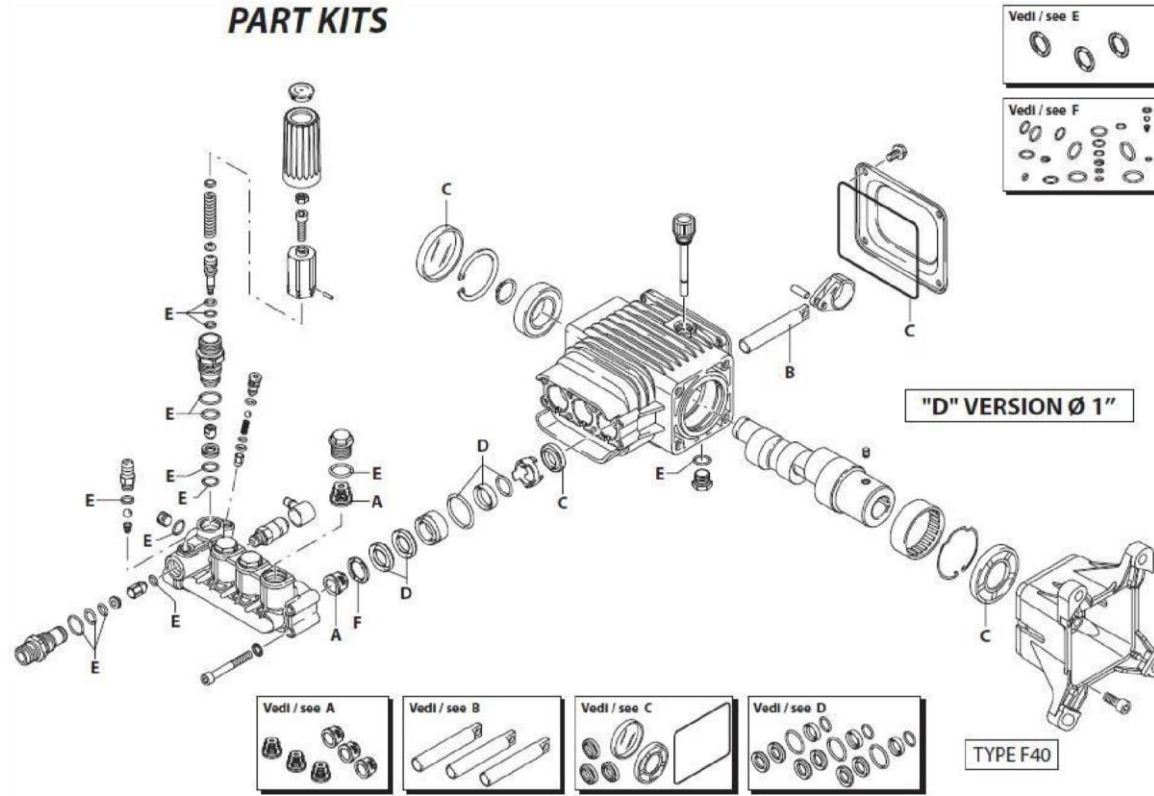

A = KIT 42666 VALVES		E = KIT 2190 O-RINGS			
POS	QTY	POS	QTY	POS	QTY
35	6	7	1	21	1
<b>B = KIT 2187 PISTONS</b>		8	1	22	1
POS	QTY	9	1	26	1
51	3	11	4	83	1
<b>C = KIT 2188 OIL SEALS</b>		12	2	85	11
POS	QTY	15	1	86	3
44	3	17	1		
46	1	<b>F = KIT 2191 SUPPORT RINGS</b>			
54	1	POS	QTY		
64	1	36	3		
<b>D = KIT 2189 WATER SEALS</b>					
POS	QTY				
37	3				
38	3				
40	3				
41	3				
42	3				



## 13. MAINTENANCE

13.1. The user should take the table below into consideration make sure the machine is kept in perfect working condition.

Item	Check	FREQUENCY				
		Every Time	First Month or 20 hours	Every season or 50 hours	Every 6 months or 100 hours	Every year or 300 hours
Engine Oil	Oil level check	○				
	Replace		○		○	
Pump oil	Oil level check	○				
	Replace		○		○	
Air cleaner	Check	○				
	Clean			○ *	○ *	
	Replace					○ *
Sparkplug	Clean, Adjust				○	
	Replace					○
Idling	Check, adjust					○
Valve clearance	Check, adjust					○
Fuel tank and Fuel filter	Clean					○
Fuel Supply line	Check					○

13.2. **NOTES** \* = More often than in schedule if the unit is used in dusty conditions.

13.2.1. **CAUTION** Only use parts supplied by the manufacturer in order to reduce the risk of damage to the machine.

13.2.2. **WARNING** Before servicing ensure that the machine is completely switched off and ensure that there is good ventilation in the area.

13.2.3. **ENGINE OIL REPLACEMENT** Draining the engine oil whilst the engine is still hot allows for a drainage that is quick and easy. Remember to check the drain plug is securely fastened again after draining. When disposing of old oil and oil containers please do so at a recycling station for environmental reasons.

## 14. DECLARATION of CONFORMITY

### EC DECLARATION OF CONFORMITY

The undersigned, as authorised by: **Genpower Ltd**

Declares that the following equipment manufactured under licence by Hyundai Korea

Conforms to the Directive: -  
**2000/14/EC (as amended)**

of the European Parliament and of the council on the approximation of the laws of the Member States relating to the noise emission in the environment by equipment for use outdoors.

Equipment Category: **High Pressure washer**

Product Name/Model: **Hyundai HYW2500P, HYW3000P, HYW3100P,  
HYW3100P2, HYW4000P**

Type/Serial No: **Petrol High pressure washer**

Net installed power: **HYW2500P = 3.7, HYW3000P = 3.7, HYW3100P = 3.7,  
HYW3100P2 = 3.7, HYW4000P = 7.2**

The technical documentation is kept by: **Roland Llewellyn, Genpower Ltd,  
Isaac Way, Pembroke Dock,  
Pembrokeshire, SA72 4RW.**

The conformity assessment procedure followed was in accordance with annex V of the Directive.

Notified Body: **TÜV SÜD Product Service GmbH,  
Zertifizierstelle, Riddlerstraße 65,  
80339 MÜNCHEN, Germany.  
Certification n° M8A 13 07 84794001**

Measured Sound Power Level: **HYW2500P = 108, HYW3000P = 109, HYW3100P = 108,  
HYW3100P2 = 109, HYW4000P = 112.**

Guaranteed Sound Power Level: **HYW2500P = 108, HYW3000P = 109, HYW3100P = 108,  
HYW3100P2 = 109, HYW4000P = 112.**

A copy of this certificate has been submitted to the European Commission and to EU Member State United Kingdom.

Place of Declaration: **Pembroke Dock, SA73 4RW**

Date: **28/06/2013**

Signed by: **Roland Llewellyn** *RJLlewellyn*

Position in Company: **Director**

Name and address of manufacturer or Authorised representative:

**Genpower Ltd,  
Isaac Way, Pembroke Dock,  
Pembrokeshire, SA72 4RW.**



## **15. CONTACT DETAILS**

<b>Address</b>	Genpower Limited, Isaac Way, Pembroke Dock, Pembrokeshire, SA72 4RW, UK.
<b>Telephone</b>	++44 (0) 1646 687880
<b>Fax.</b>	++44 (0) 1646 686198.
<b>Email contact; Technical</b>	service@genpower.co.uk
<b>Web site;</b>	www.hyundaipowerequipment.co.uk











# **HYUNDAI**

**POWER PRODUCTS**

**Importer:**

**GENPOWER LTD**

**Isaac Way, London Road**

**Pembroke Dock, UNITED KINGDOM, SA72 4RW**

**T: +44 (0) 1646 687 880 F: +44 (0) 1646 686 198**

**E: [info@hyundaipowerproducts.co.uk](mailto:info@hyundaipowerproducts.co.uk)**

**[www.hyundaipowerproducts.co.uk](http://www.hyundaipowerproducts.co.uk)**

**Imported/Distributed by GENPOWER LTD for The United Kingdom & Ireland**

**Licensed by Hyundai Corporation, Korea**